



inprocess 

Inprocess Training Dossier

Document Control

Document Title	Inprocess Training Dossier
Date	12 December 2024
Document Reference	2025.0
Author (s)	Josep Anton Feliu & Marc Massó

Commercial Contact

Oriol Millan

Inprocess Technology & Consulting Group, S.L.
Pedro i Pons, 9-11 13th floor · E-08034 BARCELONA

Tel: +34 933 308 205
Fax: +34 933 308 206
e-mail: oriol.millan@inprocessgroup.com

Table of Contents

Table of Contents.....	3
1. Introduction.....	6
1.1. Inprocess Training Courses Advantages	6
1.2. Inprocess Training Catalogue.....	7
2. Training Approach	8
2.1. Three-way training approach to process simulation	8
3. Inprocess Training & Software Support Expertise	9
3.1. Marc Massó.....	9
3.2. Dr. Josep Anton Feliu.....	9
3.3. Dr. Miquel Àngel Alós.....	9
3.4. Manel Serra	9
3.5. Dr. Daniel Cortés	10
3.6. José María Ferrer	10
3.7. Dr. Miguel Ángel Navarro	10
3.8. Muskilda Pascualena.....	10
3.9. Hanneliese Freites	10
3.10. Saeid Mokhatab (external consultant).....	11
3.11. Dr. Mayte Mota	11
3.12. Dr. Jordi Pla.....	11
3.13. Luis Imaz	11
4. Training courses delivery models.....	12
4.1. Standard Classroom Training.....	12
4.2. Virtual Classroom Training.....	12
4.3. 2+2 Training.....	13
4.4. Inprocess Knowledge Improvement Programme (KIP).....	13
4.5. Custom Training Courses	14
4.6. Inprocess Training Programme.....	14
4.7. Training follow-up	15

5.	Inprocess Standard Training Courses	16
	Process Simulation Courses	16
5.1.	SC-SS01 - Introduction to Steady State Process Simulation	16
5.2.	SC-SS11 - Steady State Process Simulation (Oil & Gas Focus)	18
5.3.	SC-SS12 - Steady State Process Simulation (Natural Gas and LNG Focus)	22
5.4.	SC-SS13 - Steady State Process Simulation (Refinery Focus)	26
5.5.	SC-SS14 - Steady State Process Simulation (Petrochemicals Focus)	28
5.6.	SC-SS15 - Introduction to Steady State Process Simulation (Chemicals focus)	30
5.7.	SC-DS02 - Simulation for Process Control Engineers	33
5.8.	SC-DS01 - Introduction to Dynamic Process Simulation	38
5.9.	SC-DS14 - Dynamic Process Simulation (Petrochemicals Focus)	42
5.10.	SC-SS02 - Advanced Steady State Process Simulation	44
	Technology Courses	46
5.11.	TC-SS01 - Simulation of Natural Gas Transmission and Processing	46
5.12.	TC-DS01 - Process Control for Process Engineers using Dynamic Simulation	50
5.13.	TC-SS03 - Flare System Modelling	54
5.14.	TC-SS04 - Designing and Rating Heat Exchangers	56

TRAINING

Training is an essential element for any organization's success. Inprocess has a commitment to quality and a reputation of excellence making sure we offer you cost-effective complete training solutions.

Courses delivered by Inprocess staff have helped process technicians, engineers, and scientists to understand and apply innovative simulation techniques. We are able to offer both standard and tailored training courses using real world examples.

Inprocess offers a broad variety of training services for implementation, maintenance and updating of knowledge on process simulation technology.

Inprocess courses:

- Offer training in the use of Process Simulators as well as acquiring the engineering knowledge and industry best practices to obtain the largest possible benefits from these tools.
- Are directed at improving your ability and confidence in the use of technology, in parallel with a deeper understanding of the processes with the object of solving industry problems as efficiently as possible.

CUSTOMIZED FOR YOU

Inprocess uses a modular approach to courses and seminars. This allows us to readily change the amount of emphasis on specific areas or to add, subtract, or re-order modules with minimal effort. Some of our most popular combinations of modules are available in pre-packaged sets:

- Introduction to Steady State Process Simulation
- Improving Refinery Operations through Process Simulation
- Process Control for Process Engineers using Dynamic Simulation

The courses we offer are tailored to specific industries, for example we have courses based on the offshore oil and gas industry, the refining industry or the air separation industry. In addition, customization with specific examples and content for your plant is available as well.

LEARNING BY DOING

Our courses are based on hands-on training. Theory is introduced and covered to the extent necessary to ensure understanding of correct principles for practical use. However, the real heart of the material focuses on the many aspects of application of knowledge to the plant. Principles are presented, and then examined in application in case studies from actual operating units.

Training is held in small groups to increase involvement and keep everyone's interest high. Our training helps operators and engineers to optimize a broad range of different process units by:

- Selected examples, meaningful for your units, emphasizing the basic points and showing how to approach real problems and produce results.
- Course sections customized to fit your plant and process to improve applicability and knowledge retention.

1. Introduction

The Inprocess Training Overview document has been compiled to reflect the diversity of the process simulation user community concerning the level of existing expertise as well as the type of applications and processes the tools are applied to.

The Training Programmes described here can be further customized to the client's exact needs – e.g. depending on the number of engineers to be trained and/or to focus on a specific technology.

1.1. Inprocess Training Courses Advantages

The following aspects positively influence the quality and effectiveness of Inprocess' Process Simulation Training Courses:

- **Experience of Trainer:** Inprocess uses only trainers with a minimum of 5 years of relevant process simulation experience (3 years for basic courses). This ensures that most questions asked by the attendees during a training course can be answered.
- **Quality of Course Content and Training Material:** The training courses have been recently developed based on more than 30 person-years of training experience.
- **Three Way approach:** Combination of underlying chemical and process engineering foundations with software knowledge and its application to real world examples makes the learning extremely effective and ensures the concepts acquired are fully consolidated
- **Process-specific content:** If needed, Inprocess offers training courses specific to one family of processes – e.g. refining.
- **Flexibility:** The Inprocess Training Programme can be used as a "Training Tool-Box" and client-specific training module combinations with a specific focus (e.g. compressors) can be developed. Furthermore, it is possible to develop additional modules based on client's own examples
- **Language:** The courses can be carried out in English, French, Italian, and Spanish – improving the effectiveness of the technology transfer.

1.2. Inprocess Training Catalogue

			Days	Level			Vertical					
				Basic	Intermediate	Advanced	Upstream (Oil&Gas)	Natural Gas & LNG	Oil Refining	Petrochemicals	Chemicals	Engineering
Process Simulation Courses	SC-SS01	Introduction to Steady State Process Simulation	3	X			X	X	X	X		X
	SC-SS11	Steady State Process Simulation (Upstream focus)	3	X	X		X					X
	SC-SS12	Steady State Process Simulation (Natural Gas focus)	3	X	X			X				X
	SC-SS13	Steady State Process Simulation (Oil refining focus)	3	X	X				X			X
	SC-SS14	Steady State Process Simulation (Petrochemicals focus)	3	X	X					X		X
	SC-SS15	Steady State Process Simulation (Chemicals Focus)	2	X							X	X
	SC-DS02	Simulation for Process Control Engineers	3+1	X			X	X	X	X		X
	SC-DS01	Introduction to Dynamic Process Simulation	3	X			X	X	X	X		X
	SC-DS14	Dynamic Simulation of Petrochemical Processes	3		X					X		X
	SC-SS02	Advanced Steady State Process Simulation	2			X	X	X	X	X		X
Other Courses	TC-DS01	Process Control for Process Engineers using Dynamic Simulation	3	X			X	X	X	X		X
	TC-SS01	Simulation of Natural Gas Transmission and Processing	5	X				X				X
	TC-SS03	Flare Systems Modelling	1	X			X	X	X	X		X
	TC-SS04	Designing and Rating Heat Exchangers	2	X			X	X	X	X		X

2. Training Approach

2.1. Three-way training approach to process simulation

When training engineers in the use of process simulation software, it is important to not only focus on the software aspects of the technology, but also to consider the underlying engineering technology (which might have been forgotten) and its application to real-life problems. This three-way approach is visualized in Figure 1 and Figure 2 below:

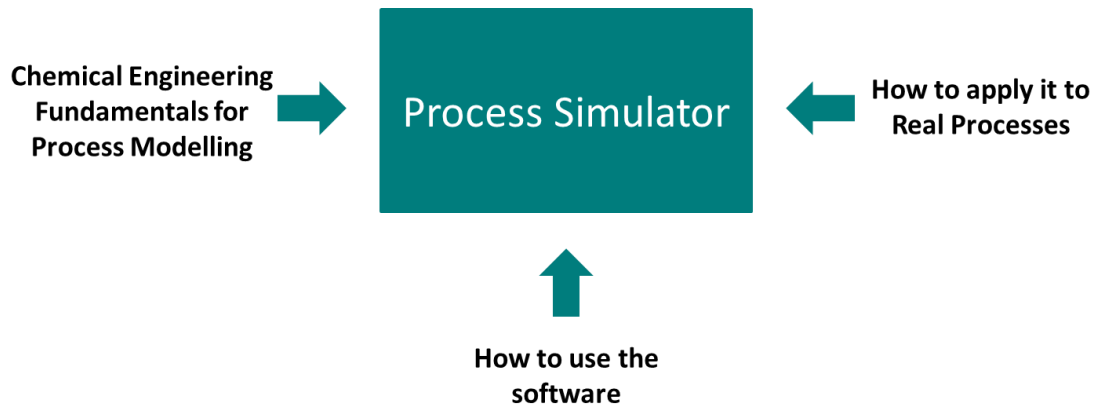

FIGURE 1. THREE WAY APPROACH TO PROCESS SIMULATION TRAINING

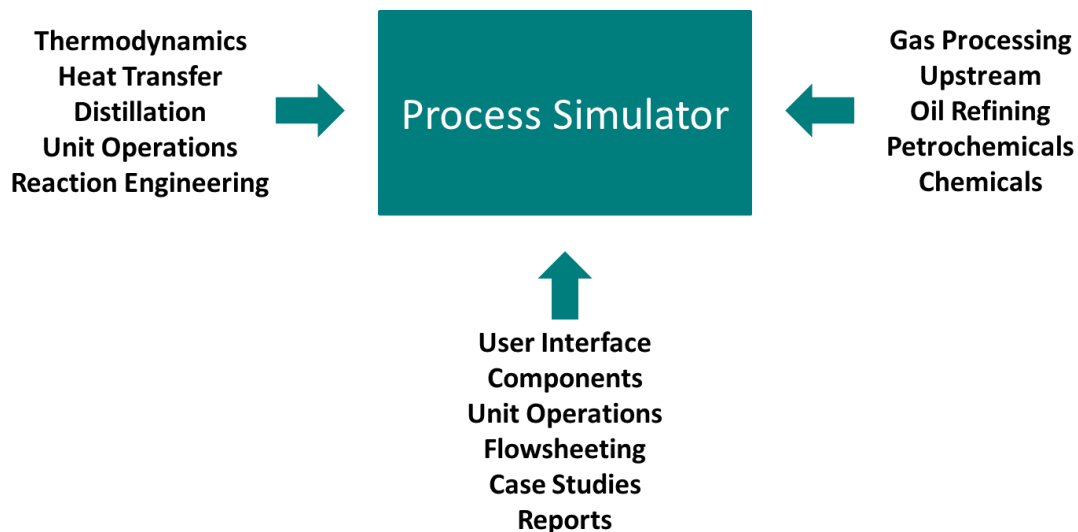

FIGURE 2. EXAMPLES FOR EACH OF THE THREE DIMENSIONS OF THE THREE-WAY APPROACH

When missing any one of these three aspects, it is likely that the technology training will not deliver to its expectation. All Inprocess Training Modules that make up our standard training courses are considering all three aspects in an integrated way – ensuring that the training goals are achieved.

3. Inprocess Training & Software Support Expertise

Inprocess' engineers have been involved in developing and delivering training in Process Simulation (steady state & dynamic) and related disciplines to the major energy companies. Inprocess' engineers have been developing and managing training programs in ENI, Shell, CEPESA, Repsol, Saudi Aramco, BP, BASF, UBE Chemicals, Technip and others. Specific examples are Educational Programmes on Oil Refining, Gas Compression and Modelling of off-shore Oil & Gas platforms.

Mr. Marc Massó is Inprocess' Training Product Manager. Mr. Massó's task is supported by Dr. Josep Anton Feliu in all coordination aspects and by a number of senior process modelling instructors. Summaries of their backgrounds are given below:

3.1. Marc Massó

Marc has over fifteen years of experience in the use of dynamic and steady state process simulators. With a solid background in fluid dynamics simulation, he has participated in several oil & gas dynamic simulation projects in order to determine optimal operating points of complex compression systems and exploration and production platforms, study of complex control loops, PSV revalidations and flare studies as well as OTS development for refinery and chemical plants. He has also been involved in complex full GTL plant development and control strategy evaluation.

3.2. Dr. Josep Anton Feliu

Josep Anton has over twenty years of experience in modelling and simulating oil & gas, refining, petrochemical, chemical and biochemical processes using both commercial and purpose-built simulators. Preparation and delivery of educational programs has been as well a constant activity during these years. For the last fifteen years he has provided world-wide customer support and training for steady state and dynamic process simulation and has participated as simulator advisor for several modelling services projects. He has also been associated professor at Universitat Autònoma de Barcelona (UAB).

3.3. Dr. Miquel Àngel Alós

Miquel Àngel has over twenty years of experience in simulation projects of chemical processes and in the delivery of educational training programmes. In Inprocess, Miquel Angel works as Senior Advisor focusing mainly on Dynamic Simulation Projects. Before, at Hyprotech and AspenTech, he provided worldwide Customer Support and Training for HYSYS and for Hyprotech's batch processes lifecycle solutions. He also was driving simulation projects for supporting and teaching oil & gas, refining, petrochemical and chemical process simulation users. He has also been associated professor at Universitat Ramon Llull (Institut Químic de Sarrià).

3.4. Manel Serra

Manel has over fifteen years of experience in Process Simulation and in the development and integration of model-based solutions. During his work at Hyprotech and AspenTech, he was part of the Upstream Global Services team, where he implemented and delivered monitoring and optimization solutions for Exploration and Production customers. Manel has also experience in the implementation of open standards (CAPE-OPEN, OPC) and agent technology as well as process modelling training experience for Steady State and Dynamic Simulation.

3.5. Dr. Daniel Cortés

Daniel has over 8 years of experience in research and university lecturing. His expertise focuses on automation and computer-assisted solutions, particularly the use of commercial simulators combined with optimization techniques to enhance industrial processes and supply chains. He also has postdoctoral experience in data science and programming. At Inprocess he has also enhanced our training portfolio for operations (ITOP and INGENO) and is engaged within the services department in projects from Refinery, both in Steady State and Dynamics.

3.6. José María Ferrer

José María has over twenty years of experience in the dynamic simulation and control of hydrocarbon processes. After completing his MSc. Electrical Engineering degree, in 1995 he began his career as Process Control engineer being Operator Training System (OTS) business development leader. He has executed several dynamic simulation projects covering Emergency ShutDown (ESD) verification and Advanced Process Control (APC). He has also overseen several dynamic simulation projects supporting APC implementations.

3.7. Dr. Miguel Ángel Navarro

Miguel Ángel has over ten years of experience in the use of dynamic and steady state process simulators along with optimization processes. He has participated in several refining steady state and dynamic simulation projects in order to analyse complex design of pressure relief systems for refinery plants as well as operation of different kinds of distillation columns (cokers, azeotropic, vacuum, atmospheric, reactive...). He has also been involved in the development of OTS (Operator Training System) for reactive distillation of an azeotropic column and studies on gas oil processes.

3.8. Muskilda Pascualena

Muskilda has near eight years of experience in modelling and simulating Oil & Gas, Refining and Petrochemical processes using commercial simulators due to different fields of work experience. Her role in the Customer Support department of Aspentech for EMEA region, not only assisting users but also delivering training courses, provided her technical skills in Aspen Plus, Aspen Properties, ACM, HYSYS and family related products. She later worked as process engineer developing simulation models for a gasification process engineering company. Since she joined Inprocess in 2018, she has taken part as Services Engineer in modelling services project (Steady State and Dynamics) and training delivery.

3.9. Hanneliese Freites

Hanneliese has over 3-year experience in modelling and simulating Oil & Gas, Refining, Petrochemical, and Chemical processes using commercial simulators. She works in the modelling and service department focusing mainly on dynamic simulation projects for upstream companies. She is also responsible for the management of maintenance activities for delivered OTS; she works in the coordination of resources and actively participates in the update activities.

She has experience working as a University Professor in the Process Simulation Department, focusing on Process Control, Steady State, and Dynamic Simulation. She also has more than 10 years of experience in different Chemicals Industries.

3.10. Saeid Mokhatab (external consultant)

Saeid Mokhatab is one of the most recognizable names in the natural gas community through his contributions to advancing the technologies in the natural gas processing industry. He has been on the international advisory board of a number of petroleum/energy consulting firms around the world and has been actively involved in several large-scale gas-field development projects, concentrating on the design, pre-commissioning, and startup of processing plants.

Saeid, in collaboration with leading experts from major international EPC Contractors and famous process licensors in the field of natural gas processing, has published over 200 technical papers and 3 books, including the Elsevier's Handbook of Natural Gas Transmission & Processing, which has been very well received by professionals in the natural gas industry and academia worldwide. He founded the world's first peer-reviewed journal dedicated to the natural gas science & engineering (published by Elsevier, USA); has held editorial positions in several prestigious journals/book publishing companies for the hydrocarbon processing/LNG industry; and served as a member of technical committee for a number of professional societies and famous gas processing conferences worldwide. Because of his outstanding work in the natural gas industry, he has received a number of international awards including the Einstein Gold Medal of Honor and Kapitsa Gold Medal of Honor; and his biography has been listed in highly prestigious directories.

3.11. Dr. Mayte Mota

Mayte Mota has over 8 years of experience in modelling and simulation of Oil&Gas, Refining, Petrochemical and lignin industry using built in-house models with commercial simulators. She works in the Services Department as Project Manager leading the development of models for steady state and dynamic simulation studies as well as digital twins. Mayte's past experience as teaching assistant in top universities Khalifa University in UAE and Imperial College in London, has allowed her to combine her tasks in Services with being Instructor for Trainings in several courses at Inprocess.

3.12. Dr. Jordi Pla

Jordi Pla holds a PhD in Thermodynamics and has nearly a decade of experience in simulating a wide range of processes within the petrochemical and chemical industries. His expertise spans the assessment of flare systems, optimization of steam and water networks, and the development of detailed simulation models for distillation columns. Jordi has also played a key role in the design and implementation of Operator Training Simulators (OTS) and Digital Twins, contributing to projects from their initial stages through to successful client delivery.

In addition to his technical expertise, Jordi has teaching experience from his time as a lecturer at the Universitat de València during his PhD studies. He has led training sessions, delivered courses, and facilitated model handovers for clients at Inprocess.

3.13. Luis Imaz

Luis has over three years of experience in Steady State and Dynamic Process Simulation projects. He's been actively involved in Upstream and Natural Gas projects, where he has been able to apply his know-how rotating machines performance. At Inprocess, Luis apart from working in the Services department, he has been teaching several training courses with process simulation focus.

4. Training courses delivery models

Inprocess offers a variety of training delivery models. At our facilities or at client's site, the goal remains the same – share practical expertise and increase engineers' effectiveness on their daily work. We help to get the job done and put customer in control.

4.1. Standard Classroom Training

One, two or three-day classroom training helps engineers optimize the design of a broad range of different process units. Selected examples, meaningful for customers, emphasize the basic points and show how to approach real problems and produce results. Training is held in small groups to increase involvement and keep everyone's interest high. Specific sections can be customized to fit customer's plant and process to improve applicability and knowledge retention.

4.2. Virtual Classroom Training

Inprocess' Virtual Classroom courses bring together the benefits of Inprocess' training philosophy (learn by doing) and the capabilities of online-style training. Our Training experience suggests that maintaining the audience attention during a whole working day in a virtual environment might be hard, hence the modules that would cover a course day are split into morning courses of 4 hours a day, with mentor follow-up in the afternoons for the attendees that might need it.

The full-time presence of the instructor during the days of the course allows the attendees to gain a complete insight into the course concepts and simulation features, while at the same time letting them interact in a relaxed, informal way with the course instructor. With the course contents distributed over different days, in an easy-to-follow format, the project experience of Inprocess' simulation expert will facilitate the learning process of the course attendees.

Highlights of Inprocess' Virtual Classroom Courses:

- **Flexibility:** Class sessions are scheduled in half-days, for a whole 5-day week, for two reasons: firstly, to avoid an excessive and mentally-exhausting concentration on training for a full day. Experience shows that the attention of the students in the last hours of the day diminishes, making this time less productive in terms of training. Secondly, because this allows students to devote part of their time to the other tasks of their daily work. As with physical classroom courses, in-house Virtual Classroom courses' content and length can be tailored to any specific company requirements.
- **Mentorship:** For the rest of the day, when lessons are not being given, the instructor will be available to solve any doubts that the students might have and will address all questions posed by the students the following day, clarifying anything that might have remained unclear and making sure that all the main targets of the module have been achieved. This ensures that no student is left behind during their learning path.
- **Topic focus and Experience:** Inprocess' experts, with several years of experience in using process simulation to solve engineering or operational issues, will be giving the simulation lessons, focusing in each of them on the questions that are most relevant to their daily practice (e.g. distillation, rotating equipment, heat transfer, etc.). It is worth mentioning that Inprocess is a company dedicated to helping clients in using process simulation to achieve their business objectives. Therefore, the know-how of our engineers is based on an extensive problem-solving background and not only on expertise in software functionalities and user interfaces.

- **Learning assessment:** Final tests, with questions regarding the concepts addressed during the course, are available on request. This is a useful tool for companies in order to be able to track the increase in knowledge of the attendees and to keep track of their learning curve.

Virtual Classroom Training Characteristics

- **Documentation** of the course sent by email and readily available for each student in the class.
- **Easy access** to the Virtual Classroom through web browser or by downloading the WebEx app in the desktop. Invitations will be sent to each attendee after enrolment on the training course is confirmed.
- **2-way screen sharing** in real time (instructor – student; student – instructor). This facilitates solutions to any doubts or questions and makes every attendee feel part of the training experience through all the questions or issues posed.
- **Chat available** to interact with the instructor and the rest of attendees in real time. This allows Inprocess to keep a record of the questions and issues raised, ensuring that no one is “left behind” while progressing in the training.
- **Full presentation control:** Drawings, comments, arrows, highlighting and many more tools are used by the instructor to focus on the different concepts explained and demonstrated during the course. These annotations can be saved as snapshots that can be made accessible to the attendees. This ensures that the most important tips, the answers to specific questions, and everything outside the scope of the training material is kept on record for the students.
- **Student station remote control.** The online connection allows the instructor (under request) to take control of the student’s workstation. This will facilitate both the troubleshooting of individual cases and specific problem solving.

4.3. 2+2 Training

Based on Inprocess’ experience, the effectiveness of the training courses is significantly improved by adding a realistic example exercise from the attendees’ working environment with about 5-10h total work-load – to be carried out after the standard course. This exercise would be developed by Inprocess and email support is given to the attendees during the exercise period (which should be 4-6 weeks). After this period, the Inprocess trainer will come back to carry out an exercise workshop, where any open questions about the exercise will be discussed (case study results, assumptions made, specifications set, etc.). In addition, it will be possible to repeat some of the modules of the initial course or to add advanced modules.

4.4. Inprocess Knowledge Improvement Programme (KIP)

Too often, the theory taught during a standard process simulation training course is not put into practice during the subsequent weeks or months as it might not be required immediately. Therefore, the invested effort in time and money gradually dissipates. In order to create an efficient knowledge transfer process, Inprocess proposes a long-term relationship, based on the continuous development of the client’s process simulation skills set through our Knowledge Improvement Programme (KIP). The KIP is a tailored combination of educational services including model development, specific training courses, on-the-job learning projects, coaching, access to expert simulation consultancy, support for simulation deployment to operations, and any other aspect that would fit client specific needs. The programme will build the necessary foundation for knowledge acquisition and ongoing skills development in process simulation. A KIP is normally delivered as a series of independent modules to facilitate the investment and to validate the continuous success of the programme. The structure of the programme includes standard and custom modules - selected based on the needs and the resources.

4.5. Custom Training Courses

Depending on customer requirements, Inprocess also offers Custom Training Courses outside of the scope of our standard training modules. The instructors for such training are carefully selected and in case that Inprocess does not have the required expertise in-house, we select the best available external experts to ensure the training fulfils Inprocess' high training standards.

4.6. Inprocess Training Programme

For companies that want to apply a thorough process simulation training curriculum for new engineers (e.g. as part of their standard trainee programme), Inprocess has developed the “*Inprocess Training Programme*”. It includes three levels of steady state process simulation training (basic, intermediate, and advanced) and one basic level of dynamic process simulation training. Further levels of dynamic process simulation training are available on an on-demand basis. Depending on the individual training needs, it is possible to go through the whole programme within one year (one course per quarter). Nevertheless, it is also possible to only participate in the BASIC and INTERMEDIATE training – e.g. in cases where Process Simulation is not a main tool of the engineer. For training of process engineers who are already more advanced, Inprocess offers hands-on training workshops, which have been proven a very effective tool for experienced users. An overview of the *Inprocess Training Programme* is given in **Table I** below, while Figure 3 next shows the normal path that one engineer might follow in a complete training program through Inprocess' different modules.

TABLE 1. INPROCESS TRAINING PROGRAMME EXAMPLE

	BASIC SS	INTERMEDIATE SS	ADVANCED SS	BASIC DYNAMIC	PROCESS CONTROL	SIM. FOR PROC. CONT. ENG.
Course Length	3 days	3 days	2 days	3 days	3 days	3 (+1) days
Intended for	Absolute Beginners	Engineers with some experience in steady state simulator, who like to refresh their know-how	Engineers for which the simulator is a major tool for their day-to-day business, and who would like to learn some tricks of the trade	Engineers who will be using Dynamic Simulation	Process Engineers who want to enhance their knowledge in Process Control	
Pre-Requisites	Chemical Engineering background	One year of Eng. Practice Some use of a simulator... or after BASIC	Good Know-How in simulation... or after INTERMEDIATE	Good knowledge in Steady State simulation	None	Previous experience in control roles or basic knowledge about process control
Languages	English, Italian, Spanish, French	English, Italian, Spanish, French	English, Italian, Spanish, French	English, Italian, Spanish, French	English, Spanish	English, Spanish

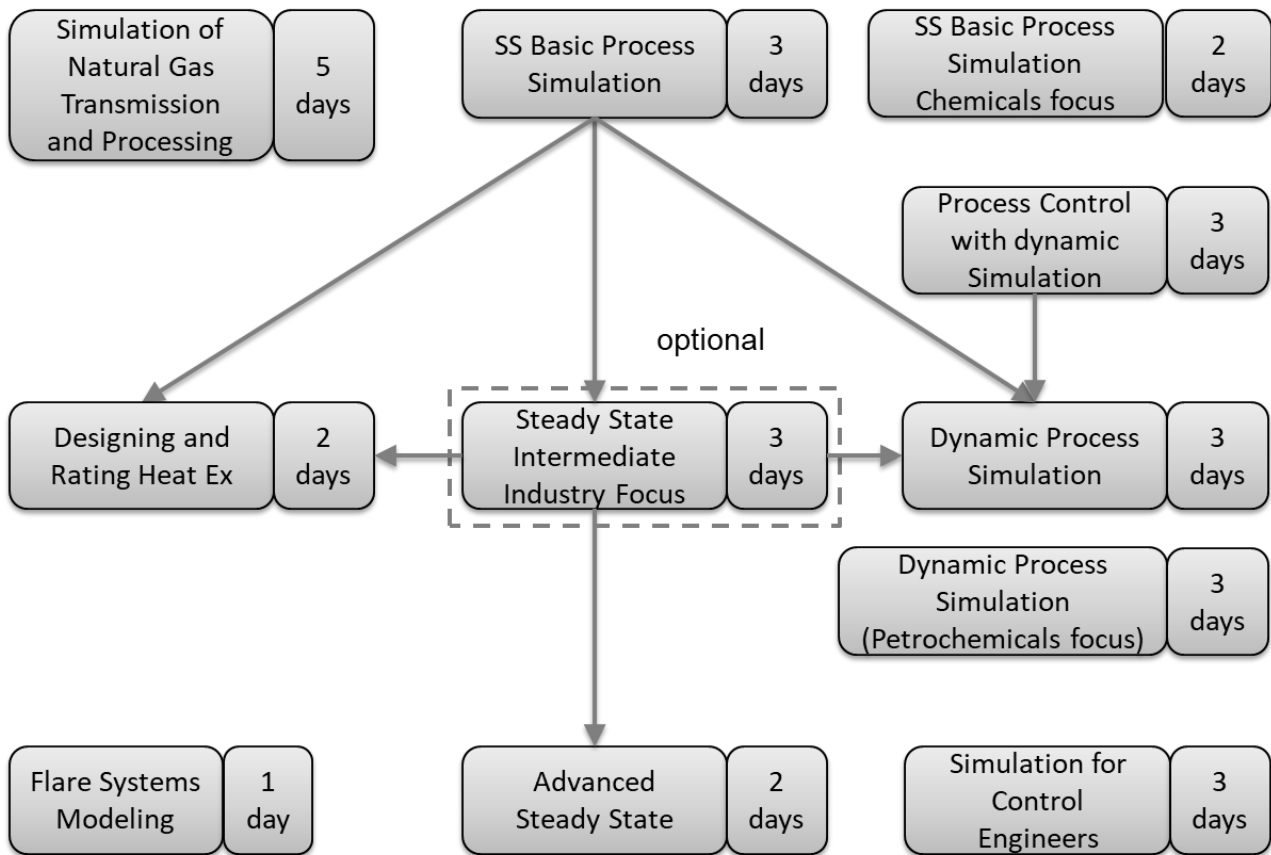

FIGURE 3. EXAMPLES OF DIFFERENT PATHS FOLLOWING A PROCESS SIMULATION TRAINING PROGRAM

4.7. Training follow-up

Inprocess offers the possibility to provide remote training follow-up support, giving assistance to engineers when applying the learned technology in their day-to-day business. This approach ensures that the new knowledge is not lost if it cannot be applied immediately.

5. Inprocess Standard Training Courses

The course agendas shown here are examples of past Inprocess training courses that have been run in-house at customers belonging to several markets. Some of the courses have a defined market focus, others have a wider scope. Although all of them make use of process simulators, some have focus on how to apply the tool, other focus more on the technology to be applied and benefited from.

Process Simulation Courses

5.1. SC-SS01 - Introduction to Steady State Process Simulation

5.1.1. Objectives

The course content covers the basic needs of process simulation users. The basic unit operations are introduced in a stepwise manner with the objective of being able to build flowsheets by the end of the course. The use of several software functionalities will show users how to explore operating alternatives for the processing plant units that are being studied. The course has been designed to include many hands-on exercises to facilitate a more efficient and interesting learning experience. Theory is used to introduce the objectives of every module in the course as well as to help attendees to understand how the underlying calculations are performed.

5.1.2. Participants

This course is intended for engineers beginning to use process simulation as well as for those who already use it but who need a refresher to experiment with new software features or extend the applications they use process simulation for. The workshops have been designed with an increasing complexity, in order to help in developing the attendees' learning curve.

The course content is aimed at process engineers, control engineers, safety and environmental engineers, planning engineers and engineers from other departments where process simulation is or could be in use.

5.1.3. Contents

The concepts acquired during the course will allow engineers to build their own process simulation cases to solve problems in their daily design studies. Basing decisions on rigorous simulation results will lead to better and quicker decision-making and furthermore, to improve confidence in the decisions taken.

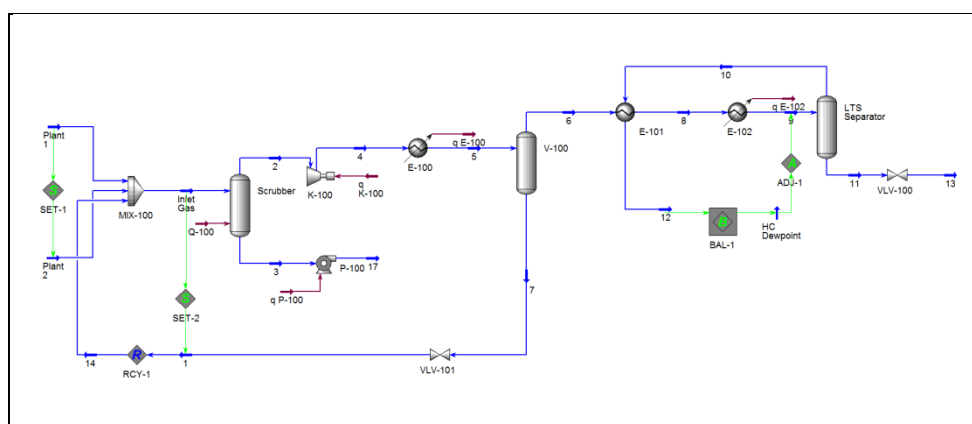

5.1.4. Three-day agenda

MODULE	MODULE TITLE AND SHORT DESCRIPTION	TIME	DAY
1	INTRODUCTION TO THE PROCESS SIMULATOR Working with an existing case. Getting used to GUI elements. Setting-up a user preferences file. How to work with fluid streams. How to install stream utilities. How to install and connect unit operations. The Degrees Of Freedom concept.	3 hours	Day 1
2	BASIC THERMODYNAMICS Creating a new case. How to select components for a simulation: Traditional - hypothetical. The need for thermodynamic correlations and methods.	1 hour	
3	HEAT TRANSFER UNIT OPERATIONS Heaters, Coolers, Shell & Tube Heat Exchangers. Air coolers. Design calculations. Rating simulations.	2 hours	
4	REPORTING Exploring how to extract the results obtained in the simulation calculations by the generation of internal reports or by exporting them to a third software.	1 hour	
5	LOGICAL OPERATORS, SPREADSHEET & CASE STUDY Additional mathematical tools sometimes needed to drive the simulation results to the desired optimal or conditional solution. Set. Adjust. Balance. Recycles. Use of the internal Spreadsheet to enhance the level of possible flowsheet calculations. Sensitivity Analysis (Case Study Tool).	4 hours	Day 2
6	DISTILLATION COLUMNS Distillation columns: How to install, define and solve distillation columns. Absorbers. Condensers and Reboilers. Column Design. Column Sizing.	3 hours	
7	REACTIONS AND REACTORS How to define several types of reactions. How to use them inside reactors in the flowsheet. Basic reactors (conversion, equilibrium, Gibbs). CSTRs. PFRs.	3 hours	Day 3
8	COMPRESSORS, PUMPS AND PIPELINES Simulation of compressors and pumps, with and without curves. Calculation of outlet conditions. Modelling of pipelines for pressure drop and heat transfer calculations.	3 hours	
9	ECONOMIC EVALUATION In order to develop the most economical design of a process or a unit, not only must the production and the purity be considered, but the operating costs as well. The use of internal spreadsheet will enhance the level of possible flowsheet and economical calculations. Case Studies for Sensitivity Analysis.	2 hours	

5.2. SC-SS11 - Steady State Process Simulation (Oil & Gas Focus)

5.2.1. Objectives

The course content covers the needs of process simulation users in an Oil & Gas working or designing environment. The use of several software functionalities will show users how to explore operating alternatives for the processing plant units that are being studied. The concepts acquired during the course will allow engineers to build their own process simulation cases to solve design problems in their daily job. Basing decisions on rigorous simulation results will lead to better and quicker decision-making and furthermore improve confidence in the decisions taken.

5.2.2. Participants

The course is aimed at engineers who are involved in the design, control and operation of Oil & Gas processing facilities. Therefore, the course content is also applicable for process engineers, control engineers, safety, and environmental engineers involved in roles and tasks, where process simulation is in use.

5.2.3. Contents

The course has been designed to include many hands-on exercises to facilitate a more efficient and interesting learning experience. Theory is used to introduce the objectives of every module in the course as well as to help attendees to understand how the underlying calculations are performed.

5.2.4. Customized levels

The course content can be adapted to suit an audience of engineers new to the process simulation as well as to an audience of engineers who have used the software in the past. The course agenda shown in table 5.2.5 below offers a first course day with basic content ideal for beginners. However, for more advanced users, the modules proposed for this first day, can be substituted with the modules proposed in table in point 5.2.6.

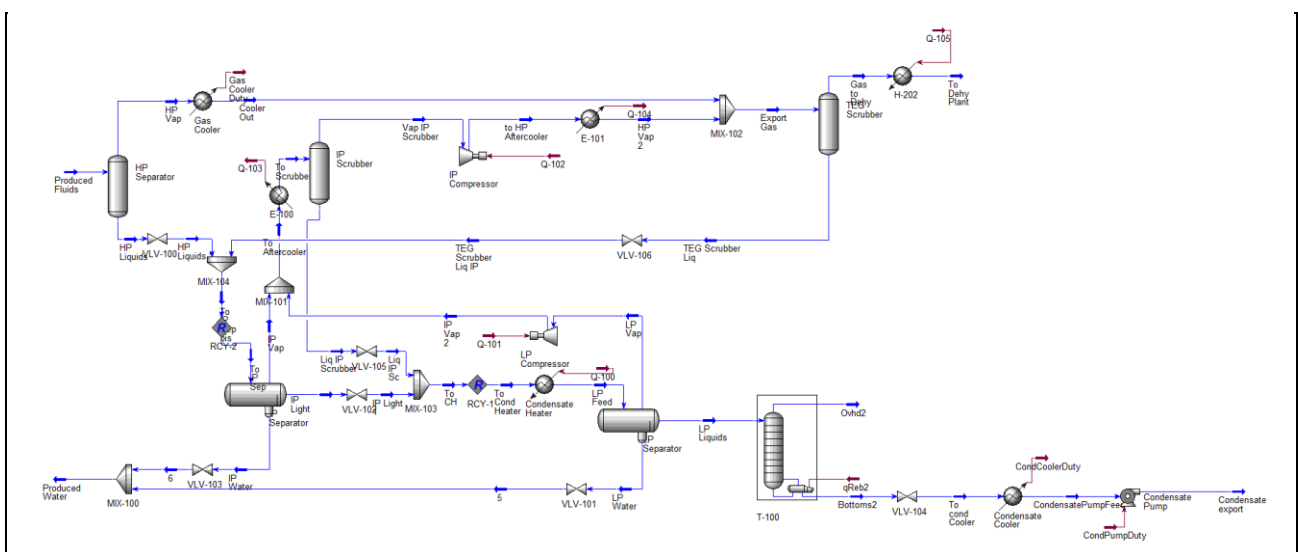

5.2.5. Three-Days Course Agenda

MODULE	MODULE TITLE AND SHORT DESCRIPTION	TIME	DAY
1	INTRODUCTION TO THE PROCESS SIMULATOR Working with an existing case. Getting used to GUI elements. Setting-up a user preferences file. How to work with fluid streams. How to install stream utilities. How to install and connect unit operations. The Degrees Of Freedom concept.	3 hours	Day 1
2	BASIC THERMODYNAMICS Creating a new case. How to select components for a simulation: Traditional - hypothetical. The need for thermodynamic correlations and methods.	1 hour	
3	HEAT TRANSFER UNIT OPERATIONS Heaters, Coolers, Shell & Tube Heat Exchangers. Air coolers. Design calculations. Rating simulations.	2 hours	
4	DISTILLATION COLUMNS Distillation columns: How to install, define and solve distillation columns. Absorbers. Condensers and Reboilers. Column Design. Column Sizing.	2 hours	
5	PHASE ENVELOPES AND PHASE BEHAVIOUR Analysis of different phase envelopes according to fluid composition. Expected production. Expected behaviour. Influence of heavy components.	1 hour	Day 2
6	RESERVOIR FLUIDS CHARACTERIZATION Methods for oil characterization in the basis environment. Exploration of software alternatives for limited data availability.	2 hours	
7	PRODUCTION GATHERING Intensive use of the Pipe Segment to calculate separation plant inlet conditions, estimate well conditions, evaluate pressure drops and heat losses for different types of pipe insulation.	2 hours	
8	PQ CURVES SIMULATION Use of extensions to be able to simulate the evolution of wells with time due to depletion, when PQ curves are known.	2 hours	
9	HYDRATES FORMATION AND INHIBITION Use of the existing utility to evaluate the possible formation of hydrates and exploration of methods to depress them and avoid its formation.	3 hours	Day 3
10	PHASE SEPARATION AND STABILIZATION Building a separation plant to obtain the phases that constituted the inlet fluid. Liquids stabilization by distillation.	3 hours	
11	NATURAL GAS DEHYDRATION WITH TEG Construction of a dehydration plant to dehydrate a gas stream using triethylene glycol. Evaluate optimal plant operation conditions.	1 hour	

5.2.6. Additional Available Related Modules

MODULE	MODULE TITLE AND SHORT DESCRIPTION	TIME	DAY
Option	MULTISTAGE GAS COMPRESSION Rigorous simulation of a multistage gas compression unit. Determination of optimal working condition as a function of intermediate pressure values.	2 hours	
Option	REFRIGERATION LOOPS STUDIES Analysis of the effect of pressure drops in refrigeration loops. Determination of optimum intermediate pressures for economizer. Impurities effects.	2 hours	
Option	NATURAL GAS LIQUIDS EXTRACTION AND FRACTIONATION Natural Gas Liquids are extracted by LTS technology. Recovery of light hydrocarbons by successive distillation. Column Design.	3 hours	

5.3. SC-SS12 - Steady State Process Simulation (Natural Gas and LNG Focus)

5.3.1. Objectives

The course content covers the needs of process simulation users in a Natural Gas processing working or designing environment. The use of several software functionalities will show users how to explore operating alternatives for the processing plant units that are being studied. The concepts acquired during the course will allow engineers to build their own process simulation cases to solve design problems in their daily job. Basing decisions on rigorous simulation results will lead to better and quicker decision-making and furthermore improve confidence in the decisions taken.

5.3.2. Participants

The course is aimed at engineers who are involved in the design, control and operation of any Natural Gas processing facility. Therefore, the course content is also applicable for process engineers, control engineers, safety, and environmental engineers involved in roles and tasks, where process simulation is in use.

5.3.3. Contents

The course has been designed to include many hands-on exercises to facilitate a more efficient and interesting learning experience. Theory is used to introduce the objectives of every module in the course as well as to help attendees to understand how the underlying calculations are performed.

5.3.4. Customized levels

The course content can be adapted to suit an audience of engineers new to the process simulation as well as to an audience of engineers who have used the software in the past. The course agenda shown in table 5.3.5 below offers a first course day with basic content ideal for beginners. However, for more advanced users, the modules proposed for this first day, can be substituted with the modules proposed in table in point 5.3.6.

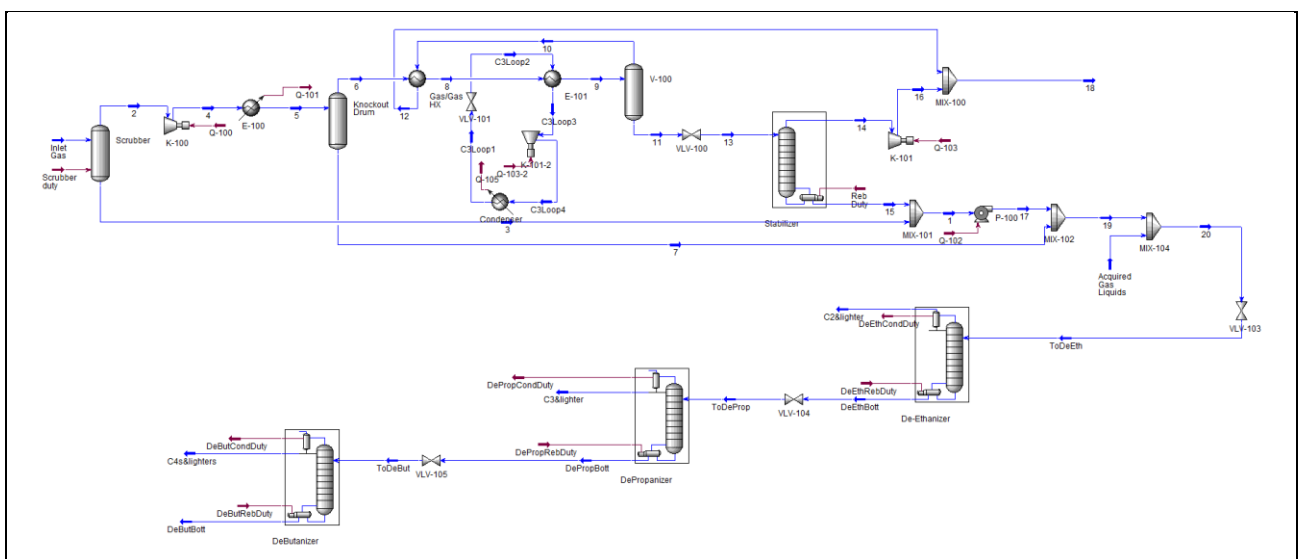

5.3.5. Three-Days Course Agenda

MODULE	MODULE TITLE AND SHORT DESCRIPTION	TIME	DAY
1	INTRODUCTION TO THE PROCESS SIMULATOR Working with an existing case. Getting used to GUI elements. Setting-up a user preferences file. How to work with fluid streams. How to install stream utilities. How to install and connect unit operations. The Degrees Of Freedom concept.	3 hours	Day 1
2	BASIC THERMODYNAMICS Creating a new case. How to select components for a simulation: Traditional - hypothetical. The need for thermodynamic correlations and methods.	1 hour	
3	HEAT TRANSFER UNIT OPERATIONS Heaters, Coolers, Shell & Tube Heat Exchangers. Air coolers. Design calculations. Rating simulations.	2 hours	
4	DISTILLATION COLUMNS Distillation columns: How to install, define and solve distillation columns. Absorbers. Condensers and Reboilers. Column Design. Column Sizing.	2 hours	
5	PHASE SEPARATION AND STABILIZATION Building a separation plant to obtain the phases that constituted the inlet fluid. Liquids stabilization by distillation.	3 hours	Day 2
6	NATURAL GAS DEHYDRATION WITH TEG Construction of a dehydration plant to dehydrate a gas stream using triethylene glycol. Evaluate optimal plant operation conditions.	1 hour	
7	LTS, LTX AND EXPANDER ALTERNATIVES Evaluation of process alternatives to process a gas to obtain a desired quality in terms of dew point or Wobbe index. External refrigeration, valve expansion and expander are evaluated.	3 hours	
8	NATURAL GAS LIQUIDS EXTRACTION AND FRACTIONATION Natural Gas Liquids are extracted by LTS technology. Recovery of light hydrocarbons by successive distillation. Column Design.	3 hours	Day 3
9	A TURBO EXPANDER PLANT FOR ETHANE RECOVERY Construction of a turbo-expander plant for deep recovery of ethane from a natural gas stream. Heat recovery network is built in a separate subflowsheet.	1 hour	
10	CASCADE REFRIGERATION PROCESS FOR NG LIQUEFACTION These facilities use the classical cascade cycle where three refrigeration systems are employed: propane, ethylene and methane.	3 hours	

5.3.6. Additional available related modules

MODULE	MODULE TITLE AND SHORT DESCRIPTION	TIME	DAY
Option	MULTISTAGE GAS COMPRESSION Rigorous simulation of a multistage gas compression unit. Determination of optimal working condition as a function of intermediate pressure values.	2 hours	
Option	REFRIGERATION LOOPS STUDIES Analysis of the effect of pressure drops in refrigeration loops. Determination of optimum intermediate pressures for economizer. Impurities effects.	2 hours	
Option	MIXED REFRIGERANT PROCESS FOR NG LIQUEFACTION The Mixed Refrigerant Cycle (MRC) system uses a single mixed refrigerant composed of nitrogen, methane, ethane, propane, butane and pentane.	2 hours	
Option	PRECOOLED MIXED REFRIGERANT PROCESS FOR NG LIQUEFACTION The propane precooled mixed refrigerant process was developed from a combination of the cascade and mixed refrigerant processes.	2 hours	

5.4. SC-SS13 - Steady State Process Simulation (Refinery Focus)

5.4.1. Objectives

The course content covers the needs of process simulation users in an oil refinery working or designing environment. The use of several software functionalities will show users how to explore operating alternatives for the processing plant units that are being studied. The concepts acquired during the course will allow engineers to build their own process simulation cases to solve design problems in their daily job. Basing decisions on rigorous simulation results will lead to better and quicker decision-making and furthermore improve confidence in the decisions taken.

5.4.2. Participants

The course is aimed at engineers who are involved in the design, control and operation of Oil Refinery facilities. Therefore, the course content is also applicable for process engineers, control engineers, safety, and environmental engineers involved in roles and tasks, where process simulation is in use.

5.4.3. Contents

The course has been designed to include many hands-on exercises to facilitate a more efficient and interesting learning experience. Theory is used to introduce the objectives of every module in the course as well as to help attendees to understand how the underlying calculations are performed.

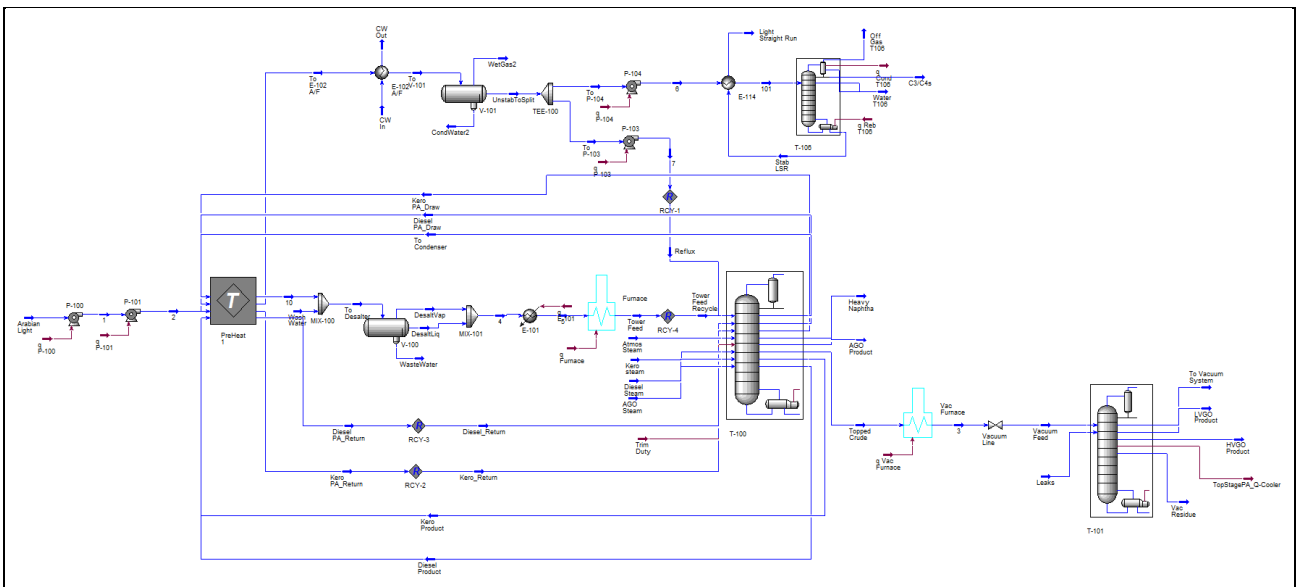

5.4.4. Three-Days Course Agenda

MODULE	MODULE TITLE AND SHORT DESCRIPTION	TIME	DAY
1	INTRODUCTION TO THE PROCESS SIMULATOR Working with an existing case. Getting used to GUI elements. Setting-up a user preferences file. How to work with fluid streams. How to install stream utilities. How to install and connect unit operations. The Degrees Of Freedom concept.	2 hours	Day 1
2	BASIC THERMODYNAMICS Creating a new case. How to select components for a simulation: Traditional - hypothetical. The need of thermodynamic correlations and methods.	1 hour	
3	REFORMER STABILIZER In a naphtha reformer unit the effluent from the catalytic reformer reactor needs to be stabilized before further processing. Simple unit operations.	2 hours	
4	REFINERY DISTILLATION COLUMNS Experimenting with the different capabilities of the simulator to solve the distillation problems usually encountered in refinery modelling.	2 hours	
5	OIL CHARACTERIZATION How to use laboratory data and analysis to define a crude oil or a final product in order to be used in the simulation case.	2 hours	Day 2
6	MODELLING A CRUDE/VACUUM SYSTEM WITH PRE-HEAT TRAIN The simulation model of an integrated Crude/Vacuum system, with preheat train, will be constructed and its performance examined.	5 hours	
7	MODELLING A FCC MAIN FRACTIONATOR AND GAS PLANT The model for the main fractionator column of a Fluid Catalytic Cracking unit will be modelled together with the associated gas concentration unit.	4 hours	Day 3
8	HYDROCRACKER SIMULATION An example of a typical hydrocracker unit will be modelled, consisting in the feed heating section, an approximate reactor model, the product cooling section, the HP separator and the recycle gas stripper.	3 hours	

5.5. SC-SS14 - Steady State Process Simulation (Petrochemicals Focus)

5.5.1. Objectives

The course content covers the basic needs of petrochemical plants process simulation users. The basic unit operations are introduced in a stepwise manner with the objective of being able to build flowsheets by the end of the course. The use of several software functionalities will show users how to explore operating alternatives for the processing plant units that are being studied.

The course has been designed to include many hands-on exercises to facilitate a more efficient and interesting learning experience. Theory is used to introduce the objectives of every module in the course as well as to help attendees to understand how the underlying calculations are performed.

5.5.2. Participants

This course is intended for engineers beginning to use process simulation as well as for those who already use it but who need a refresher to experiment with new software features or extend the applications they use process simulation for. The workshops have been designed with an increasing complexity, in order to help in developing the attendees' learning curve.

The course content is aimed at process engineers, control engineers, safety and environmental engineers, planning engineers and engineers from other departments where process simulation is or could be in use.

5.5.3. Contents

The concepts acquired during the course in the calculation of distillation columns, reactors, heat exchangers, etc. as well as validating the adequacy of thermodynamic packages and parameters will allow engineers to build their own process simulation cases for their daily design, process and energy improvement or troubleshooting studies. Basing decisions on rigorous simulation results will lead to better and quicker decision making and furthermore improve confidence in the decisions taken.

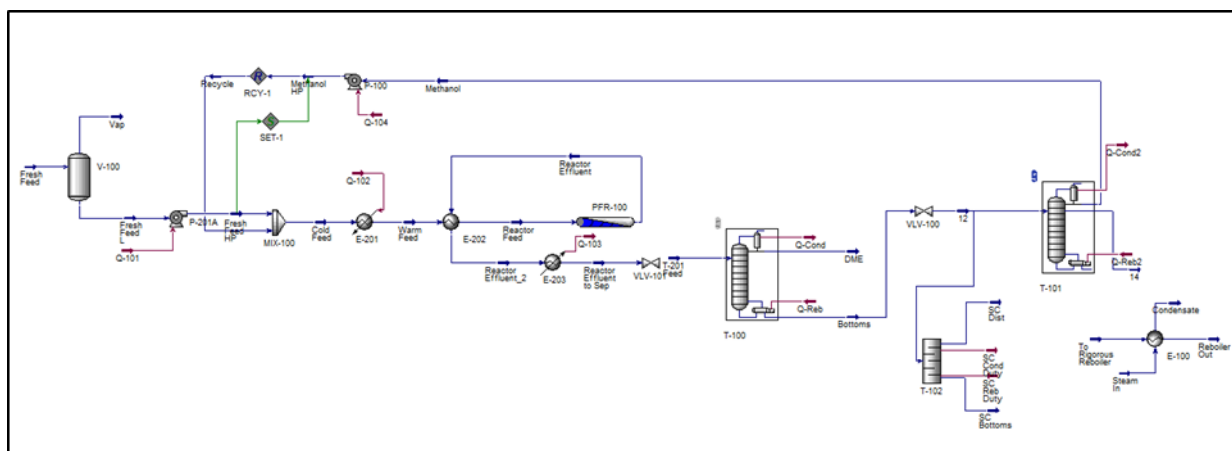

5.5.4. Three-Days Course Agenda

MODULE	MODULE TITLE AND SHORT DESCRIPTION	TIME	DAY
1	INTRODUCTION TO THE PROCESS SIMULATOR Working with an existing case. Getting used to GUI elements. Setting-up a user preferences file. How to work with fluid streams. How to install stream utilities. How to install and connect unit operations. The Degrees Of Freedom concept.	2 hours	Day 1
2	BASIC THERMODYNAMICS Creating a new case. How to select components for a simulation: Traditional - hypothetical. The need of thermodynamic correlations and methods. The importance of binary interaction parameters.	2 hours	
3	HEAT TRANSFER UNIT OPERATIONS (RAFFINATE COOLER) Heaters, Coolers, Shell & Tube Heat Exchangers. Air coolers. Design calculations. Rating simulations.	3 hours	
4	REACTIONS AND REACTORS (SYNTHESIS DIMETHYL ETHER) How to define several types of reactions. How to use them inside reactors in the flowsheet. Basic reactors (conversion, equilibrium, Gibbs). CSTRs. PFRs.	4 hours	Day 2
5	INTRODUCTION TO DISTILLATION COLUMNS (SEPARATION DIMETHYL ETHER) Distillation columns: How to install, define and solve distillation columns. Absorbers. Condensers and Reboilers. Use the design basic calculations for a new distillation column.	3 hours	
6	ADVANCED DISTILLATION COLUMNS (SEPARATION DIMETHYL ETHER) Evaluation of column hydraulics. Modification of distillation column subflowsheets. Rigorous calculation of condensers and reboilers. Use of the Recycle Unit operation.	2 hours	
7	COMPRESSORS, PUMPS AND PIPELINES (ETHYLENE PLANT COMPRESSION) Simulation of compressors and pumps, with and without performance curves. Use of Adjust mathematical operator. Copy and paste flowsheet operations. Templates. Modelling of pipelines for pressure drop and heat transfer calculations.	3 hours	Day 3
8	ECONOMIC EVALUATION In order to develop the most economical design of a process or a unit, not only must the production and the purity be considered, but the operating costs as well. The use of internal spreadsheet will enhance the level of possible flowsheet and economical calculations. Case Studies for Sensitivity Analysis.	2 hours	
9	DISTILLATION COLUMN ADDITIONAL ASSIGNMENT Without a guided exercise, build elements of a petrochemical plant using the unit operations and tools described in the previous exercise.	4 hours	

5.6. SC-SS15 - Introduction to Steady State Process Simulation (Chemicals focus)

5.6.1. Objectives

The course content covers the basic needs of process simulation users. The basic unit operations are introduced in a stepwise manner with the objective of being able to build flowsheets by the end of the course. The use of several software functionalities will show users how to explore operating alternatives for the processing plant units that are being studied.

The concepts acquired during the course will allow engineers to build their own process simulation cases to solve problems in their daily design studies. Basing decisions on rigorous simulation results will lead to better and quicker decision making and furthermore improve confidence in the decisions taken.

5.6.2. Participants

This course is intended for chemical and process engineers beginning to use Aspen Plus as well as for those who already use it but who need a refresher to experiment with new software features or extend the applications they use process simulation for.

The course content is aimed at process engineers, control engineers, safety and environmental engineers, planning engineers and engineers from other departments where process simulation is or could be in use.

5.6.3. Contents

The course has been designed to include many hands-on exercises to facilitate a more efficient and interesting learning experience. Theory is used to introduce the objectives of every module in the course as well as to help attendees to understand how the underlying calculations are performed.

5.6.4. Two-days Course Agenda

MODULE	MODULE TITLE AND SHORT DESCRIPTION	TIME	DAY
1	INTRODUCTION TO THE PROCESS SIMULATOR Modeling and simulation of steady-state processes in the more general framework of Computer Aided Process Engineering and of specialized software tools. During this module, the following topics will be covered: <ul style="list-style-type: none"> • Introduction • Starting with Aspen Plus • The Basic Workflow • Checking of Simulation results 	1 hour	Day 1
2	PHYSICAL PROPERTIES Key concepts required to solve the mass and energy balances of steady-state processes with the techniques of process flow-sheeting. The content of the module covers the following topics: <ul style="list-style-type: none"> • Handling of components • Property Methods • Property Analysis • Property Estimation 	3.5 hours	
3	UNIT OPERATIONS AND MODEL ANALYSIS TOOLS The attendees are introduced to the new features of Aspen Plus program and take the first hands-on experience with sequential-modular resolution of recycles thanks to the supplied exercises. The content of the module covers the following topics: <ul style="list-style-type: none"> • Available Blocks • Simple Models • Simulation & Report Options • Sensitivity Analysis • Design Specifications • Calculator Blocks. 	3.5 hours	
4	DISTILLATION This module examines, in more detail, the unit operations modeling features of Aspen Plus for the benefit of engineers. The following topics are covered <ul style="list-style-type: none"> • Introduction • DISTL • DTWU • Radfrac 	3 hours	Day 2
5	REACTORS This module examines the reactor modeling features of Aspen Plus with the different options available. The following topics are covered <ul style="list-style-type: none"> • Simple Models <ul style="list-style-type: none"> ○ Rstoich ○ RYield ○ Requil ○ RGibbs • Rigorous Models <ul style="list-style-type: none"> ○ Kinetic Reactors • Reactions & Reactions Set 	2.5 hours	

MODULE	MODULE TITLE AND SHORT DESCRIPTION	TIME	DAY
6	HEAT EXCHANGERS This module examines in more detail the heat exchangers modeling features of Aspen Plus. The following topics are covered <ul style="list-style-type: none">• Heater Block• HeatX Block	1.5 hours	
7	CONVERGENCE The features of Aspen Plus to converge the flowsheet are explored in this module. The following topics are covered: <ul style="list-style-type: none">• Tear Stream• Convergence Blocks	1 hours	

5.7. SC-DS02 - Simulation for Process Control Engineers

5.7.1. Objectives

Process Engineers are heavy users of simulation tools (Aspen HYSYS®, Aspen Plus®, Honeywell UniSim®, etc.) to design new processes or revamps, and mostly all simulation training courses are designed for them. On the other hand, there are almost no specific simulation courses targeted for process control engineers, who can make use of the simulation tools to perform specific control tasks with the help of a simulator.

This course is conceived with the following objectives in mind:

- Learn the basic use of a steady-state simulator and their uses in process control (Gain calculation, property calculation, inferential development, etc.).
- Given a steady state model, be able to convert it to a dynamic model with the associated control loops (i.e.: distillation column).
- Given a dynamic model, be able to change the control loops configuration to perform dynamic analysis.
- Make use of all the control features included in a dynamic simulator (i.e.: On/Off, PID, Feed-forward, split-range, selector, transfer function, etc.).
- Make use of the tools and tricks inside the dynamic simulator to carry out process control analysis.
- All the modules of the course are 100% practical and every attendee is individually using the simulator in his/her own PC, it is a "learn by doing" course. The instructor will only spend 5-10 minutes at the beginning of every the module to explain the exercises in the manual of the course.
- All the modules are developed over the same distillation column, which has been taken from a real column of an existing plant. Therefore, real plant problems and constraints when attempting to simulate plant units are reproduced (lack of data, required detail, lack of time, etc.).

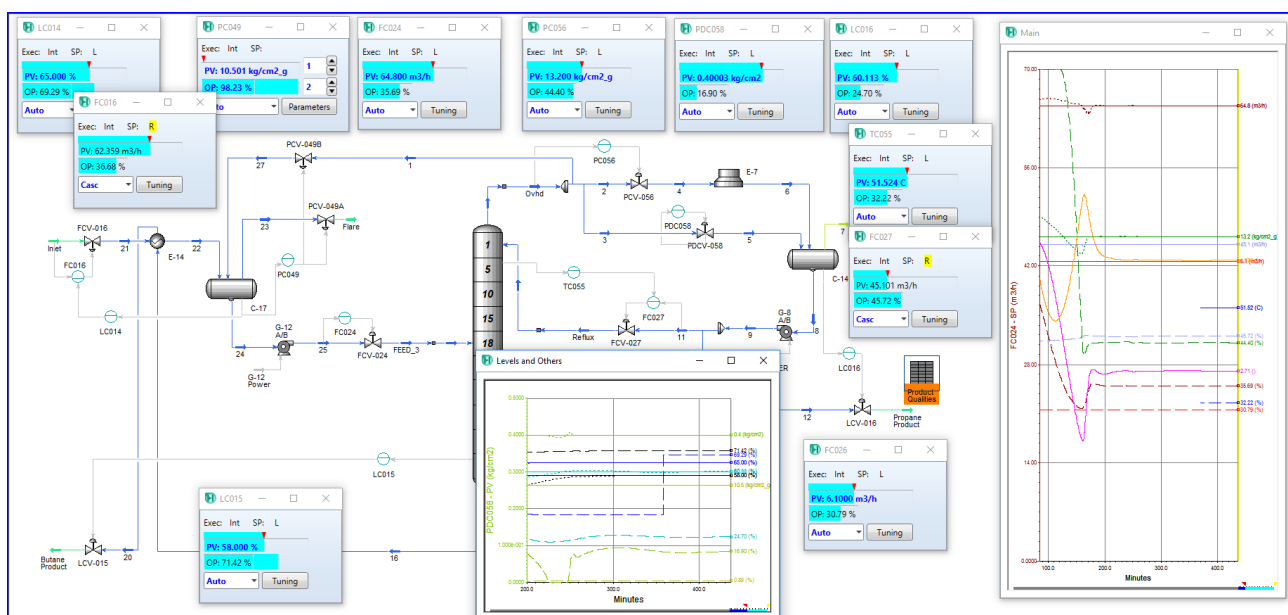

5.7.2. Participants

This course is aimed at process control engineers who are involved in the design, implementation and operation of any control system in a plant. No previous contact with process simulation software is required. The attendee should know basic chemical engineering principles (or equivalent plant experience) and process control fundamentals. It is also desirable knowledge of control/operation of distillation columns and 1-2 years of experience in process control roles.

5.7.3. Contents

During the course, control engineers will learn the fundamentals of Steady State and Dynamic Process Simulation concepts and will practice with them, always from the point of view of a Control Engineer. The concepts acquired during the course will allow control engineers to make use of simulation tools for the development of basic and advanced control layer. The modules are prepared to approach the analysis to the given process making use of the different features of the simulator such as the Case Study to calculate gains or the event scheduler that will led to perform different case scenarios to see how the model behaves. Furthermore, the exercises show how to extract and use the available data in order to take the best advantage of the software capabilities. Some of the features that will be seen in the course are related to: distillation columns, sensitivity analysis, control strategy (feed forward, ratio controllers, split-range, master/slave...), function blocks, etc.

5.7.4. Four-days course agenda

MODULE	MODULE TITLE AND SHORT DESCRIPTION	TIME*	DAY
1	CREATING A STEADY-STATE MODEL A simple steady-state case of a real distillation column is created from basic data available at the plant. Details about simulator user interface, workflow, etc. Using different column specifications (reflux ratio, tray temperature, purity, etc.) to reproduce the degrees of freedom of the column. Use of mixers/tees to reproduce feed compositions. Extracting and visualizing data from the model (column profiles, tables) as a function of a variable.	4 hours	Day 1
2	USING A STEADY-STATE MODEL FOR GAIN ANALYSIS AND PROPERTY ESTIMATION Configuration of the "Case Study" functionality inside the simulation to perform sensitivity analysis of the built column for independent vs. dependent variables. Extraction of the data to Excel. Calculation of the Steady-State gains and non-linearity of the process. Another sensitivity analysis over the column is performed in order to obtain a regression of the product quality based on column pressures and temperatures.	3 hours	
3	TRANSITIONING A STEADY-STATE MODEL INTO A DYNAMIC MODEL Discussion of the main differences between the two simulation modes (Steady-State vs Dynamic) with regards to specifying equipment and flowsheet details. Concepts of Dynamic Simulation: Pressure-Flow solver, Pressure nodes, resistance equipment, etc. Rules for transitioning from a solved steady-state model to a dynamics one. Transition of the distillation column model to Dynamics mode. The column is ready for the next day to be operated with all the valves in manual mode.	4 hours	Day 1 / Day 2
4	ACTIVATING PID CONTROLLERS IN THE DYNAMIC MODEL Operation of the column in Manual mode for few minutes. Introducing basic PID controllers and split range controller into the model for automatic mass-energy balance regulation. Use of faceplates and trending stripcharts. Introduce basic perturbations to the model. Simulator PID object features. Basic tuning of column PID controllers. Optional: use of a commercial tuning tool.	3 hours	Day 2
5	CONFIGURING AN ON-OFF CONTROLLER Learn how to build and configure on-off controllers.	0.5 hour	
6	CONFIGURING A MASTER-SLAVE CONTROLLERS Learn how to build and configure cascade controllers in the distillation column model and test their benefits. Level-Flow control. Tray temp-reboiler duty control. Tune the new cascades.	1.5 hours	
7	CONFIGURING RATIO CONTROLLERS AND SELECTOR BLOCK Learn how to build and configure in the distillation column a Ratio controller and override logic structures for different operation purposes.	1 hours	
8	CONFIGURING A FEED-FORWARD CONTROLLER Learn how to build and configure a Feed-forward controller for the reboiler duty to anticipate column load changes.	1 hour	

MODULE	MODULE TITLE AND SHORT DESCRIPTION	TIME*	DAY
9	USING THE TRANSFER FUNCTION BLOCK Learn the multiple purpose uses of the transfer function block (TFB). Using TFB as signal generator for perturbations. Using TFB as a noise generator. Using TFB as a dead-time in analyser signal. Create a filter for a process variable in a spreadsheet.	2 hours	Day 3
10	ADDING DETAILS TO THE DYNAMIC MODEL Learn how to configure a number of useful options in the simulator to increase the fidelity of the model with the real plant. This includes: Valve Characteristic, Elevation and hydraulic Static Head contribution, equipment nozzles, level taps, actuators of the control valves, heat losses, and valve stiction.	2 hours	
11	USING THE EVENT SCHEDULER Learn how to configure the event scheduler to run automatically a sequence of events, for example to simulate a sequence of automatic steps for MVs-FFs.	1 hour	
12	EXTRACTING DATA FROM THE DYNAMIC SIMULATION Learn how to configure the case to perform simulation runs and extract the data in formatted files.	1 hour	
13	IMPORTING EXTERNAL PROCESS DATA TO THE SIMULATION Learn how to configure and use a simulation macro to import historic process data from an Excel file as a boundary condition or controller Set-Point of a dynamic simulation. Applied case to the Feed Flow of the distillation column.	2 hours	
14	COMPARING PERFORMANCE OF TWO DIFFERENT CONTROL LAYOUTS Learn how to duplicate the dynamic process model to compare simulation runs with different control settings. Applied case to the built distillation column.	1 hour	

5.7.5. Additional Optional Modules

MODULE	MODULE TITLE AND SHORT DESCRIPTION	TIME*	DAY
15	<p>CONFIGURING SIMULATED INFERENTIALS IN THE DYNAMIC MODEL</p> <p>Learn how to setup the unbiased and biased inferentials calculations to reproduce the same calculations performed in the AspenIQ modules and verify the accuracy of the implemented inferentials and their tuning parameters.</p>	1.5 hours	Option
16	<p>CONFIGURING AN ASPEN DMCPLUS CONTROLLER IN HYSYS: STEP-TESTING</p> <p>Learn how to use the DMCplus controller object within HYSYS to perform virtual step-test in the built column distillation model of the simulator. Export the formatted data for the MPC identification package.</p>	1.5 hours	
17	<p>IDENTIFICATION AND DEPLOYMENT OF THE ASPEN DMC3 CONTROLLER WITH HYSYS</p> <p>Import the data set generated in HYSYS and follow the basic Identification and Deployment workflow with Aspen DMC3 Builder. The connection is configured using HYSYS as an OPC Server and the controller is deployed from the DMC3 Builder application. This module will be shown by the instructor (no hands-on practice) as a review of a standard identification and deployment process and giving the instructions to link a DMC3 controller to a HYSYS Dynamic model.</p>	2 hours	

*The time for each module is an estimation and can be adjusted/modified by the instructor during the training to fulfill all the contents to be learnt.

5.8. SC-DS01 - Introduction to Dynamic Process Simulation

5.8.1. Objectives

The course content covers the basic needs of dynamics process simulation users. The attendees will learn the fundamentals of dynamic process modeling using commercial dynamic simulators and the main differences between steady state and dynamic modeling will be introduced. In addition, the necessary basic control theory will be reviewed briefly. To facilitate an efficient learning experience, all concepts will be studied based on simple and practical hands-on examples. The basic unit operations are introduced in a stepwise manner with the objective of being able to build dynamic process flowsheets by the end of the course.

Theory is used to introduce the objectives of every module in the course as well as to help attendees to understand how the underlying calculations are performed. The use of several software functionalities will show users how to explore operating alternatives for the processing plant units that are being studied.

5.8.2. Participants

This course is aimed at engineers who are involved in the design, control and operation of any processing facility. The workshops have been designed with an increasing complexity, in order to help in developing the attendees' learning curve. Although the workshop examples are taken from the Gas Processing industries, the acquired foundations on dynamic simulation can be applied to any process industry. Therefore, the course content is also applicable for process engineers, control engineers, safety, and environmental engineers in other industries, where dynamic process simulation is in use.

Important Note: Participants must be familiar with steady state process simulation to fully benefit from the subjects covered in this course.

5.8.3. Contents

The concepts acquired during the course will allow engineers to build their own process simulation cases to solve problems in their daily design studies. Basing decisions on rigorous simulation results will lead to better and quicker decision-making and furthermore improve confidence in the decisions taken. This course enables the attendees to use the dynamic modeling capabilities of dynamic process simulators to model and simulate typical processing facilities, showing the benefits that dynamic process simulation can bring in the day-to-day engineering and operating environment.

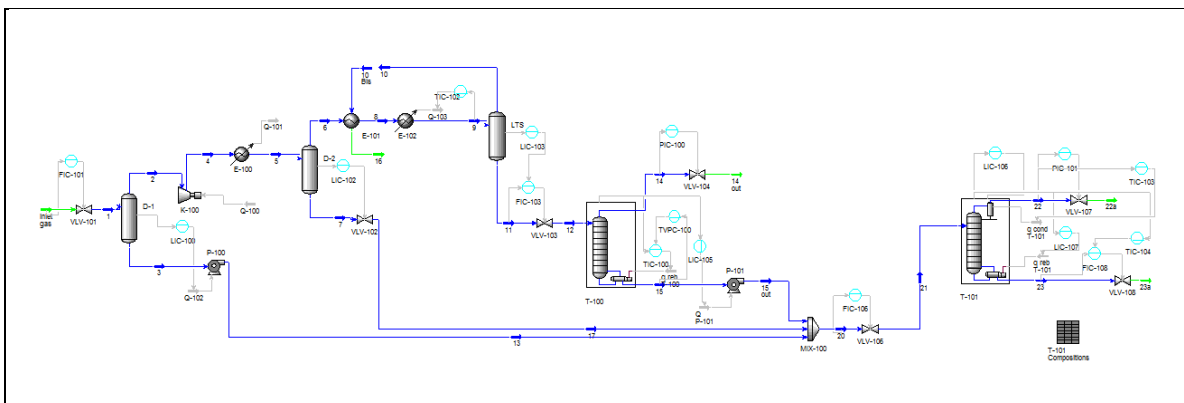

5.8.4. Three-days course agenda

MODULE	MODULE TITLE AND SHORT DESCRIPTION	TIME	DAY
1	BASIC CONCEPTS OF DYNAMIC SIMULATION Understanding the foundations of dynamic simulation using Process Simulators: The Pressure-Flow solver; Distributed and Lumped models; Pressure nodes and flow resistances.	2 hours	Day 1
2	DIFFERENCES BETWEEN STEADY-STATE AND DYNAMIC MODELS Discussion of the main differences between the two modelling modes concerning specifying equipment and flowsheet details. Rules for transitioning from a solved steady-state model to a dynamics one.	1 hour	
3	FUNDAMENTALS OF PROCESS CONTROL Open and closed loop. PID controllers and final control elements. Setup and modification of control strategies.	2 hours	
4	DYNAMIC MODEL OF AN INLET SEPARATION PLANT Development of an initial plant model in Steady State. Transition to Dynamics using equipment sizes, control valves, control loops, strip chart graphs, etc.	3 hours	
5	ENHANCED DYNAMIC SIMULATION Enhancement of previous model by incorporating additional details. Some of the defaulted values are modified and parts of the assumptions are revisited.	3 hours	Day 2
6	GAS COMPRESSION SIMULATION IN DYNAMICS Compressor maps, anti-surge control, bypass valves and other protection equipment is incorporated into the original model.	3 hours	
7	OPERATIONAL PERFORMANCE (SCHEDULING OF EVENTS) The Event Scheduler is a powerful tool that allows the dynamic modeller to plan and program several operational performance tests to monitor the response of the model in front of upsets and disturbances.	2 hours	
8	UNITS TRIPS AND COMPRESSOR PRESSURE RELIEF The robust dynamic model will be disturbed and upset by programming with the Event Scheduler unit trips and unexpected problems. The response of the protection equipment will be monitored.	2 hours	Day 3
9	MODELLING A NGL EXTRACTION PLANT Preparation of a new dynamic model of a NGL Extraction Plant. Transition from Steady State to Dynamics. Setup of level, flow and pressure PI control loops. On-off and cascade controllers are also introduced.	2 hours	
10	DYNAMIC SIMULATION OF A DISTILLATION COLUMN Expansion of the previous case by setting up a Stabilization column. A control strategy will be developed to meet the TVP specification for the NGL product	3 hours	

5.8.5. Additional Optional Modules

MODULE	MODULE TITLE AND SHORT DESCRIPTION	TIME	DAY
Option	BASIC CONTROL OF DISTILLATION COLUMNS In this module, a fractionator is added to the model and a basic control scheme for level, temperature, pressure and composition is developed and discussed.	3 hours	
Option	COLUMN PRESSURE RELIEF The standard condenser unit of the fractionator is replaced by an expanded overhead system constituted by a cooler, a separator and a pump. The system is developed in dynamics mode. Finally, a pressure relief system is configured.	2 hours	
Option	AMMONIA SYNTHESIS REACTOR How to define reactions in dynamics mode. Different types of reactors. How to simulate dynamically a PFR for the ammonia reaction.	2 hours	
Option	DYNAMIC MODELLING OF AN AMMINE CO₂ ABSORBER Using simulation to model an ammonia absorber. Solving the case in Steady-State and moving it to Dynamics. Implementation of the control system.	3 hours	
Option	MULTISTREAM HEAT EXCHANGER How to use dynamic simulation to model LNG heat exchangers. Exploring the different parameters and features of this unit operation.	3 hours	

5.9. SC-DS14 - Dynamic Process Simulation (Petrochemicals Focus)

5.9.1. Objectives

The course content covers the basic needs of dynamics process simulation users from the petrochemical and refining industries, including the modeling of chemical reactors and of complex column configurations. The attendees will learn the fundamentals of dynamic process modeling using commercial dynamic simulators and the main differences between steady state and dynamic modeling will be introduced. Also, the necessary basic control theory will be reviewed briefly. To facilitate an efficient learning experience, all concepts will be studied based on simple & practical hands-on examples. The basic unit operations are introduced in a stepwise manner with the objective of being able to build dynamic process flowsheets by the end of the course. The use of several software functionalities will show users how to explore operating alternatives for the processing plant units that are being studied, including the setup of a Cause & Effect Matrix in the simulation model to mimic the behavior of the plant Safety System

The course has been designed to include many hands-on exercises to facilitate a more efficient and interesting learning experience. Theory is used to introduce the objectives of every module in the course as well as to help attendees to understand how the underlying calculations are performed.

5.9.2. Participants

This course is aimed at engineers who are involved in the design, control and operation of any processing facility. The workshops have been designed with an increasing complexity, in order to help in developing the attendees' learning curve. Although the workshop examples are taken from the Petrochemical industries, the acquired foundations on dynamic simulation can be applied to any process industry. Therefore, the course content is also applicable for process engineers, control engineers, safety, and environmental engineers in other industries, where dynamic process simulation is in use.

Important Note: Participants must be familiar with steady state process simulation to fully benefit from the subjects covered in this course.

5.9.3. Contents

The concepts acquired during the course will allow engineers to build their own process simulation cases to solve problems in their daily design studies. Basing decisions on rigorous simulation results will lead to better and quicker decision making and furthermore improve confidence in the decisions taken. This course enables the attendees to use the dynamic modeling capabilities of dynamic process simulators to model and simulate typical processing facilities, showing the benefits dynamic process simulation can bring in the day-to-day engineering and operating environment.

5.9.4. Three-days course agenda

MODULE	MODULE TITLE AND SHORT DESCRIPTION	TIME	DAY
1	BASIC CONCEPTS OF DYNAMIC SIMULATION Understanding the foundations of dynamic simulation using Process Simulators: The Pressure-Flow solver; Distributed and Lumped models; Pressure nodes and flow resistances.	2 hours	Day 1
2	DIFFERENCES BETWEEN STEADY-STATE AND DYNAMIC MODELS Discussion of the main differences between the two modelling modes with regards to specifying equipment and flowsheet details. Rules for transitioning from a solved steady-state model to a dynamics one.	1 hour	
3	FUNDAMENTALS OF PROCESS CONTROL Open and closed loop. PID controllers and final control elements. Setup and modification of control strategies.	2 hours	
4	DYNAMIC MODEL OF THE FEED AND REACTOR SECTION OF A DME PLANT Development of an initial Di-Methyl Ether plant model in Steady State. Transition to Dynamics using equipment sizes, control valves, control loops, strip chart graphs, etc.	4 hours	
5	DYNAMIC SIMULATION OF THE COLUMN DOWNSTREAM THE REACTOR Expansion of the previous case by setting up a fractionation column for the reactor effluent. A control strategy will be developed to meet the quality specification for the column products.	4 hours	Day 2
6	ADVANCED SIMULATION ASPECTS OF THE DISTILLATION COLUMN The standard condenser unit of the fractionator is replaced by an expanded overhead system constituted by a cooler, a separator and a pump. The system is developed in dynamics mode. Cascade controllers as well as split range controllers will be installed. Finally, a pressure relief system is configured.	4 hours	
7	OPERATIONAL PERFORMANCE (SCHEDULING OF EVENTS) Several operational performance tests will be programmed and executed using the available tools in simulators to perturb the steady behaviour of the dynamic model. Use of the Event Scheduler.	2 hours	Day 3
8	THE CAUSE AND EFFECT MATRIX IN A DYNAMIC SIMULATION MODEL Preparation of the distillation dynamic model. Installation of the Cause and Effect matrix for safety implementation. Pump curves estimation. Implementation of disturbances with the transfer function operation.	4 hours	

5.10. SC-SS02 - Advanced Steady State Process Simulation

5.10.1. Objectives

The course content covers the advanced needs of process simulation users. Non-usual capabilities of the software are explored and applied to useful examples. The use of advanced software functionalities will show users how to increase the value that can be obtained from the process simulator.

The course has been designed to include many hands-on exercises to facilitate a more efficient and interesting learning experience. Theory is used to introduce the objectives of every module in the course as well as to help attendees to understand how the underlying calculations are performed.

5.10.2. Participants

This course is intended for engineers who are acquainted in the use of commercial steady state process simulators and that will benefit from a detailed explanation of some of the software advanced features.

The course content is aimed at engineers working in departments where the daily use of commercial steady state process simulators requires from them to expand their current knowledge to incorporate non-usual, but still useful, software capabilities.

5.10.3. Contents

The concepts acquired during the course will allow engineers to incorporate advanced features in their process simulation cases to solve problems in their daily design studies, improving the workflow management and reducing the project delivery time. Basing decisions on rigorous simulation results will lead to better and quicker decision-making and furthermore to improve confidence in the decisions taken.

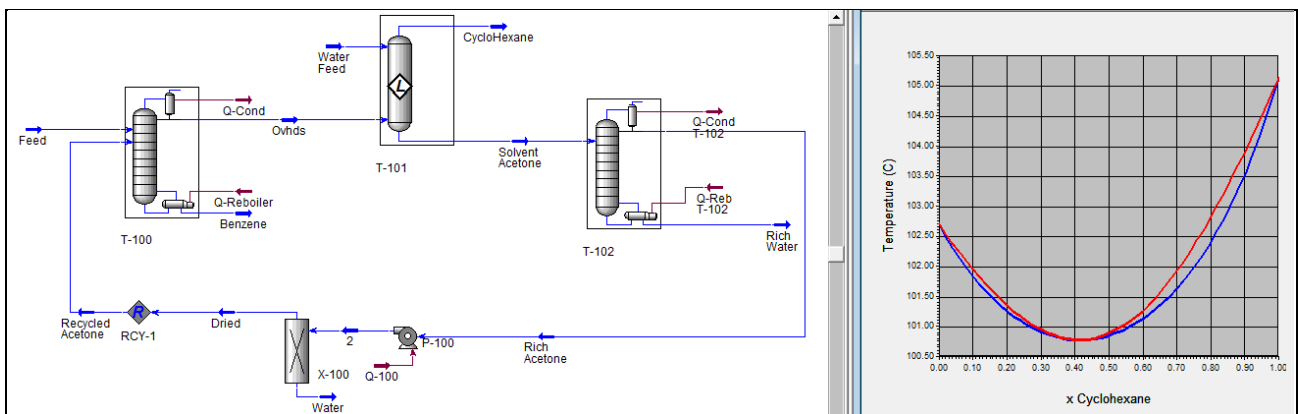

5.10.4. Two-days course agenda

MODULE	MODULE TITLE AND SHORT DESCRIPTION	TIME	DAY
1	COLUMN ENVIRONMENT MODIFICATION Advanced use of the column environment in order to modify the standard column configuration that the simulator offers by default, substituting reboilers and condensers by heaters, coolers and shell & tube heat exchangers.	3 hours	Day 1
2	ADVANCED RECYCLES AND ADJUSTS Recycles and Adjusts are powerful mathematical tools that help simulator users to find the expected solution of their problems. Some configurations require advanced modifications that will be explored in this module.	2 hours	
3	DEPRESSURING UTILITY The capability to investigate the expected behaviour of a depressuring holdup is explored using the Depressuring Utility, a Dynamic option inside the steady state version of the simulator.	2 hours	
4	ENHANCED THERMODYNAMICS Exploring some of the ways of modifying the standard setup of the simulator's thermodynamics. Using the Tabular Package it is possible to overwrite the values of physical and transport properties calculated by the selected Property Package. The use of User Properties is also explored.	1 hour	Day 2
5	OPTIMIZATION IN PROCESS SIMULATION Optimization problems are explored using both the standard SQP optimization algorithm and the enhanced SQP one that requires the setup of a Derivative utility.	3 hours	
6	ADVANCED DISTILLATION Advanced use of distillation columns in order to simulate complex problems like 3-phase, azeotropic and reactive distillation. Use of the Sparse Continuation Solver.	3 hours	
7	TROUBLESHOOTING OF CASES Analysing badly setup cases to try to investigate where the errors or mistakes are. Understanding inconsistencies. How to eliminate them.	2 hours	Option

5.11.4. Five-Days Course Agenda

Theoretical lectures are listed with numbers. Simulation exercises are listed with letters.

MODULE	MODULE TITLE AND SHORT DESCRIPTION	TIME	DAY
1	NATURAL GAS FUNDAMENTALS Introduction to Natural Gas by describing its origin and composition, gas sources, phase behavior and properties, as well as transportation methods.	1 hour	Day 1
2	RAW GAS TRANSMISSION This session covers all the important concepts of multiphase gas-condensate transmission from a fundamental perspective.	1.5 hours	
3	BASIC CONCEPTS OF NATURAL GAS PROCESSING General overview of the design and function of the different process units within a natural gas processing plant.	1.5 hours	
A	INTRODUCTION TO THE PROCESS SIMULATOR Working with an existing case. Getting used to GUI elements. Setting-up a user preferences file. How to work with fluid streams. How to install stream utilities. How to install and connect unit operations. The Degrees Of Freedom concept.	1 hour	
B	BASIC THERMODYNAMICS Creating a new case. How to select components for a simulation: Traditional - Hypothetical. The need for thermodynamic correlations and methods.	1 hour	
C	PHASE ENVELOPES AND PHASE BEHAVIOR Analysis of different phase envelopes according to fluid composition. Expected production. Expected behavior. Influence of heavy components.	1 hour	
D	PRODUCTION GATHERING Intensive use of the Pipe Segment to calculate separation plant inlet conditions, estimate well conditions, evaluate pressure drops and heat losses for different types of pipe insulation.	1 hour	
4	PHASE SEPARATION Review of the principles governing the basic separation process and to describe the commonly used separation facilities in the gas processing industry.	1 hour	Day 2
5	CONDENSATE PRODUCTION Some of the basic processes for condensate stabilization, and the associated facilities such as condensate storage, condensate hydrotreating, monoethylene glycol (MEG) regeneration and reclaiming, and sour water treatment.	1.5 hours	
6	NATURAL GAS COMPRESSION Brief overview of the two major types of compressors, a procedure for calculation of the required compression power, as well as additional and useful considerations for the design of compressors.	1.5 hours	
E	HYDRATE FORMATION AND INHIBITION Use of the existing utility to evaluate the possible formation of hydrates and exploration of methods to depress them and avoid their formation.	1 hour	

MODULE	MODULE TITLE AND SHORT DESCRIPTION	TIME	DAY
F	PHASE SEPARATION AND CONDENSATE STABILIZATION Building a separation plant to obtain the phases that constituted the inlet fluid. Condensates stabilization by distillation.	3 hours	
7	NATURAL GAS SWEETENING Basic concepts and discussion about some of today's gas sweetening problems.	1 hour	Day 3
8	SULFUR RECOVERY AND HANDLING Properties of elemental sulfur and description of some of the common methods for processing H ₂ S.	1.5 hours	
9	NATURAL GAS DEHYDRATION AND MERCAPTANS REMOVAL While this session addresses dehydration design, the different methods and configurations of mercaptans removal are also discussed at the end of it.	1.5 hours	
G	ACID GAS SWEETENING WITH AMINES Acid Gas Treating unit. Removal of acidic components by amines reaction and absorption.	1 hour	
H	MULTISTAGE GAS COMPRESSION Rigorous simulation of a multistage gas compression unit. Determination of optimal working condition as a function of intermediate pressure values.	2 hours	
I	NATURAL GAS DEHYDRATION WITH TEG Construction of a dehydration plant to dehydrate a gas stream using triethylene glycol. Evaluate optimal plant operation conditions.	1 hour	Day 4
10	NATURAL GAS LIQUIDS RECOVERY AND FRACTIONATION Production of NGL from hydrocarbon dew pointing to propane and ethane recovery, including their history, and various technologies and design options as well as NGL fractionation.	2 hours	
11	SALES GAS TRANSMISSION Important concepts of sales gas transmission from a fundamental perspective.	2 hours	
J	TURBO EXPANDER FOR ETHANE RECOVERY Construction of a turbo-expander plant for deep recovery of ethane from a natural gas stream. Heat recovery network is built in a separate subflowsheet.	1 hour	
K	NATURAL GAS LIQUIDS RECOVERY AND FRACTIONATION Natural Gas Liquids are extracted by LTS technology. Recovery of light hydrocarbons by successive distillation. Column Design.	3 hours	
12	NATURAL GAS LIQUEFACTION PROCESSES Critical overview of the process technology options available for the liquefaction of natural gas, and discusses the factors that should be considered by project developers in order to select the most appropriate process for their situation.	2 hours	Day 5
13	SELECTING BEST PROCESS TECHNOLOGY LINEUP Most commonly used process technologies for designing the gas processing units and how integration of process technologies and expert process know-how make a difference.	2 hours	

MODULE	MODULE TITLE AND SHORT DESCRIPTION	TIME	DAY
L	REFRIGERATION LOOPS Analysis of the effect of pressure drops in refrigeration loops. Determination of optimum intermediate pressures for economizer. Impurities effects.	1 hour	
M	NATURAL GAS LIQUEFACTION BY CASCADE REFRIGERATION These facilities use the classical cascade cycle where three refrigeration systems are employed: propane, ethylene and methane.	3 hours	

5.12. TC-DS01 - Process Control for Process Engineers using Dynamic Simulation

5.12.1. Objectives

Process Engineers are heavy users of simulation tools to design new processes or revamps. They mainly work in Steady-state mode, but frequently they have to interact with the Control Engineers to discuss how the process will be controlled and operated. Then, many process dynamics and control concepts need to be clearly understood by the Process Engineers to effectively design the processes and their corresponding control philosophy.

Plant designs have become increasingly complex, integrated and interactive. Heat integration, process recycles and minimum hold-ups are typical design features. Whilst such designs optimize steady state operation, they present particular challenges to control and operations engineers. Clearly, the ideal is not just to develop a working control strategy, but also to design a process that is inherently easy to control.

5.12.2. Participants

This course is aimed at process engineers who are involved in the design, control and operation of any processing facility. At the same time, process engineers in any engineering company, usually involved in basic or detailed engineering projects, will definitely benefit from the course content. Safety engineers, even junior control engineers might find useful the opportunity to experiment the classical control topics in a so powerful tool like a dynamic process simulator.

5.12.3. Contents

During the course, process engineers will learn the fundamentals of Dynamic Process Simulation concepts and will practice with them. They will as well learn the Basic Control theory and practice with it. The concepts acquired during the course will allow process engineers to make use of simulation tools (Steady State and Dynamics) for the development of the basic control layer. Thanks to this, they will be able to examine the impact of equipment sizes on process behaviour, to understand how disturbances will affect the process and to study various control schemes to find the best suited one for the process of interest.

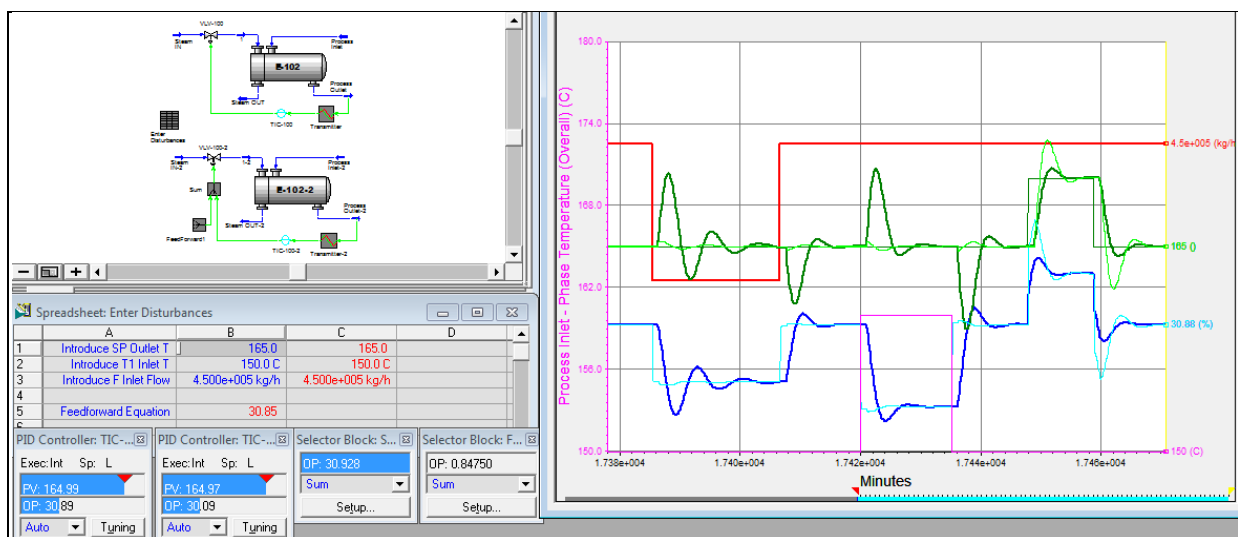

Some questions answered during the course:

- How valve's size affects the process behavior? What problems are encountered for wrongly sized valve?
- How valve characteristics changes when it is installed?
- How to identify process responses and non-linear behavior?
- What process parameter determines the ability of a process to reject, or attenuate, disturbances?
- Why process capacitance is good for disturbance rejection, but produces very slow response times?
- Why process Dead Time has no effect on the filtering capability of the process?
- When processes with Dead Time can cause problems in the control?
- What kind of processes can be covered with the Feedback control?
- What is the effect of filtering in the control response?
- What processes can benefit from the PID derivate action?
- How Buffer tanks/surge drums can help to isolate equipment from upstream disturbances?
- What are the limitations of the Feedback control, when the Feedforward control is recommended?

5.12.4. Three-days course agenda

MODULE	MODULE TITLE AND SHORT DESCRIPTION	TIME	DAY
1	INTRODUCTION TO THE DYNAMIC PROCESS SIMULATOR Working with an existing case. Getting used to GUI elements. Pressure Flow Solver and boundary specifications. Setting up a PID.	2 hours	Day 1
2	FINAL CONTROL ELEMENTS Control valve sizing, Inherent valve characteristics. Valve selection based on control performance.	2 hours	
3	FUNDAMENTALS OF PROCESS CONTROL Principles of Process Control. Single input/single output (SISO) control systems. Open and closed loops. Feedback Control. Elements of a control loop. Direct and reverse acting. Process dynamics and attributes. Capacitance and Dead time. Process responses.	3 hours	
4	PROCESS DYNAMIC GAIN, DEAD TIME AND CAPACITANCE System Identification: The Process Reaction Curve. Effects that dead time and capacitance have on system behaviour, and controllability. System attenuation capability. Use of filters and their effect in control performance.	2 hours	Day 2
5	FEEDBACK CONTROL Basic Control Modes. Setup and operation of basic single loop controllers. Choosing the right controller. PID algorithm and commercial DCS implementation forms (Honeywell, Yokogawa, Emerson, Foxboro, etc.).	2 hours	
6	CONTROLLER TUNING AND PRACTICE Tune controllers in a practical way over the dynamic simulation. Most popular tuning techniques are covered.	3 hours	
7	USING CASCADE CONTROL Learn how to build and configure a cascade controller. Students will also be able to see the benefits and limitations to this type of control scheme.	1 hour	Day 3
8	USING FEED-FORWARD CONTROLLERS Teaches students how to build and configure a Feed-forward controller. They will also be able to see the benefits and limitations to this type of control scheme.	4 hours	
9	USING RATIO CONTROLLERS, SPLIT-RANGE CONTROLLERS AND OVERRIDE SELECTORS This module teaches students on how to build and configure a Ratio and Split-range controller. They will also build override logic structures for different operation purposes.	2 hours	

5.13. TC-SS03 - Flare System Modelling

5.13.1. Objectives

Learn the fundamental flare network modeling techniques for pipeline design. Learn the basics for rating a flare convergent, divergent and looped network for the constraint violations (Mach number, MABP, Noise, velocity, RhoV2) and for pressure, temperature and flow profile throughout the network. Understand the solver messages to analyze the flow network problems and review options to take corrective measures. Review results to perform process safety studies for pressure and temperature beyond allowable range as well as erosion problems for healthiness of the flow network in the real plant. Review flare network simulation computation convergence problems and examine solver solution methods.

5.13.2. Participants

The course is intended for engineers modelling flare systems and equipment and who need training to model flow networks.

5.13.3. Contents

The course contents have been developed to allow designers to understand the way in which Flare Systems simulators work when designing, rating or de-bottlenecking flare systems. By the end of the course, attendees will be able to develop network models for convergent, divergent and looped systems.

5.13.4. One-day course agenda

MODULE	MODULE TITLE AND SHORT DESCRIPTION	TIME	DAY
1	INTRODUCTION TO THE SIMULATOR Overview of software capabilities as the tool to be used in the design of new flare networks, revamping of existing ones and to debottleneck them when new units are added to the network.	1 hour	Day 1
2	DESIGN OF FLARE NETWORKS Efficient use of the software. Flare networks design analysis. Networks optimization.	1 hour	
3	DESIGN OF A NEW SYSTEM OF FLARE NETWORK Initial simplified design of a flare network system. Rigorous simulation of the initially proposed design. Elimination of possible network restrictions.	2 hours	
4	MODIFYING AN EXISTING DESIGN Adding a new producing plant in an off-shore field to the already existing flare network. Analysis of the limitations and of the proposed solutions.	2 hours	
5	USE OF THE IMPORT/EXPORT CAPABILITIES In order to be able to reuse part of a pre-existing design or the whole of it, it is necessary to know all the tool capabilities to import and export the data existing in files.	1 hour	

5.14. TC-SS04 - Designing and Rating Heat Exchangers

5.14.1. Objectives

Among others, the objectives of this course are to learn the thermal design, rating of heat exchangers and how to use simulation to solve real process problems. To learn the fundamentals of producing a cost optimized exchanger design. Understand the basic geometric selections required to establish a practical exchanger design. Examine process side, air side, fan selection and physical properties, and investigate thermal design principles, counter current exchangers and extended surfaces.

5.14.2. Participants

This course is intended for process engineers who need a refresher in heat transfer theory and who occasionally can face the need to start the design of a new heat exchanger, to evaluate the performance of some existing one or to check a possible redesign.

5.14.3. Contents

The concepts acquired during the course will allow process engineers to incorporate heat transfer related features in their process simulation cases to solve problems in their daily design studies, improving the workflow management and reducing the project delivery time. Basing decisions on rigorous simulation results will lead to better and quicker decision-making and furthermore to improve confidence in the decisions taken.

5.14.4. Two-days course agenda

MODULE	MODULE TITLE AND SHORT DESCRIPTION	TIME	DAY
1	OVERVIEW OF HEAT TRANSFER AND HEAT EXCHANGER TYPES Theoretical session to show the most common and usual heat exchangers types. Common calculations in heat exchangers design and operation. Overview of the standard geometries of shell & tube heat exchangers. Description of the necessary items in a TEMA specification sheet.	3 hours	Day 1
2	SINGLE-PHASE HEAT EXCHANGER Instructor-led workshop showing how a single-phase heat exchanger is defined and designed in the specific heat transfer software.	2 hours	
3	CONDENSING AND BOILING How to take into account the fluids phase change when designing heat exchangers. Specific examples for condensers and reboilers	2 hours	
4	CONSIDERING HEAT TRANSFER IN PROCESS SIMULATION Generic process simulators incorporate certain simplifications and assumptions when simulating heat transfer devices. Several of this assumptions are reviewed and compared with rigorous calculations	2 hours	
5	VIBRATION ANALYSIS Overview of the types and causes of heat exchangers vibrations.	1 hour	
6	DETAILED SIMULATION OF AN EXISTING HEAT EXCHANGER Simulate an existing Heat Exchanger from its Datasheet. Use the tube layout input to correctly represent the detailed geometry.	2 hours	Day 2
7	SIMULATION OF A THERMOSIPHON REBOILER Thermosiphon reboilers are complex pieces of equipment that base all their behaviour on the correctness of their design. During this exercise a reboiler of this type will be simulated.	2 hours	
8	DESIGN A GAS-GAS HEAT EXCHANGER Design a gas-gas heat exchanger from a simulation model.	1 hour	
9	AIR COOLED HEAT EXCHANGERS Development of an air-cooled condenser with heat transfer software and analysis of the results obtained with them.	1 hour	
10	LINKING AIR COOLED HEAT EXCHANGERS IN PROCESS SIMULATION Overview of the calculations modes existing in current process simulators. Comparison with the rigorous results obtained with air cooled heat transfer software.	1 hour	