

SC-SS14: STEADY STATE PROCESS SIMULATION (PETROCHEMICALS FOCUS)

OBJECTIVES

The course content covers the basic needs of petrochemical plants process simulation users. The basic unit operations are introduced in a stepwise manner with the objective of being able to build flowsheets by the end of the course. The use of several software functionalities will show users how to explore operating alternatives for the processing plant units that are being studied.

The course has been designed to include many hands-on exercises to facilitate a more efficient and interesting learning experience. Theory is used to introduce the objectives of every module in the course as well as to help attendees to understand how the underlying calculations are performed.

PARTICIPANTS

This course is intended for engineers beginning to use process simulation as well as for those who already use it but who need a refresher to experiment with new software features or extend the applications they use process simulation for. The workshops have been designed with an increasing complexity, in order to help in developing the attendees' learning curve.

The course content is aimed at process engineers, control engineers, safety and environmental engineers, planning engineers and engineers from other departments where process simulation is or could be in use.

CONTENTS

The concepts acquired during the course in the calculation of distillation columns, reactors, heat exchangers, etc. as well as validating the adequacy of thermodynamic packages and parameters will allow engineers to build their own process simulation cases for their daily design, process and energy improvement or troubleshooting studies. Basing decisions on rigorous simulation results will lead to better and quicker decision making and furthermore improve confidence in the decisions taken.

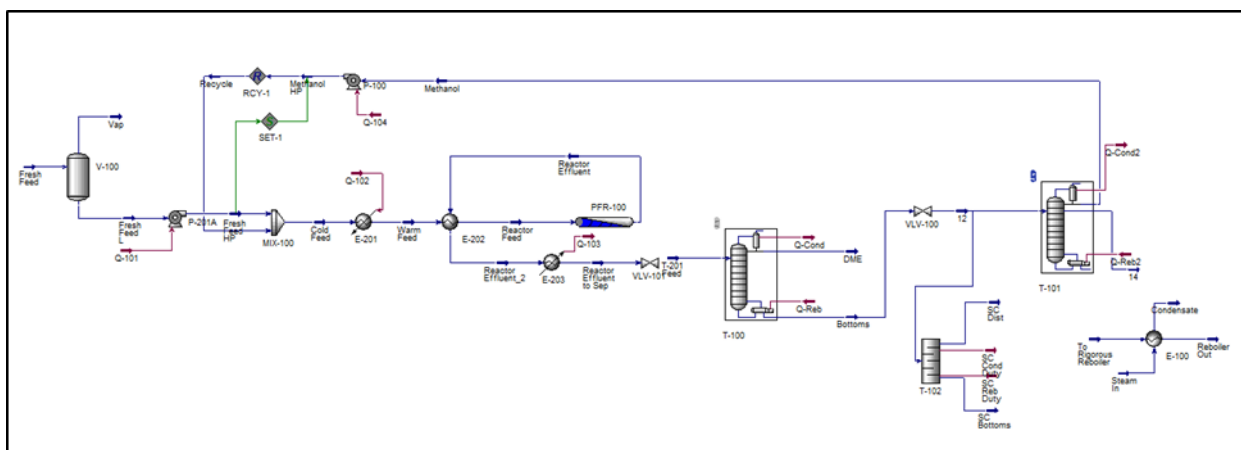

THREE-DAYS COURSE AGENDA

MODULE	MODULE TITLE AND SHORT DESCRIPTION	TIME	DAY
1	INTRODUCTION TO THE PROCESS SIMULATOR Working with an existing case. Getting used to GUI elements. Setting-up a user preferences file. How to work with fluid streams. How to install stream utilities. How to install and connect unit operations. The Degrees Of Freedom concept.	2 hours	Day 1
2	BASIC THERMODYNAMICS Creating a new case. How to select components for a simulation: Traditional - hypothetical. The need of thermodynamic correlations and methods. The importance of binary interaction parameters.	2 hours	
3	HEAT TRANSFER UNIT OPERATIONS (RAFFINATE COOLER) Heaters, Coolers, Shell & Tube Heat Exchangers. Air coolers. Design calculations. Rating simulations.	3 hours	
4	REACTIONS AND REACTORS (SYNTHESIS DIMETHYL ETHER) How to define several types of reactions. How to use them inside reactors in the flowsheet. Basic reactors (conversion, equilibrium, Gibbs). CSTRs. PFRs.	4 hours	Day 2
5	INTRODUCTION TO DISTILLATION COLUMNS (SEPARATION DIMETHYL ETHER) Distillation columns: How to install, define and solve distillation columns. Absorbers. Condensers and Reboilers. Use the design basic calculations for a new distillation column.	3 hours	
6	ADVANCED DISTILLATION COLUMNS (SEPARATION DIMETHYL ETHER) Evaluation of column hydraulics. Modification of distillation column subflowsheets. Rigorous calculation of condensers and reboilers. Use of the Recycle Unit operation.	2 hours	
7	COMPRESSORS, PUMPS AND PIPELINES (ETHYLENE PLANT COMPRESSION) Simulation of compressors and pumps, with and without performance curves. Use of Adjust mathematical operator. Copy and paste flowsheet operations. Templates. Modelling of pipelines for pressure drop and heat transfer calculations.	3 hours	Day 3
8	ECONOMIC EVALUATION In order to develop the most economical design of a process or a unit, not only must the production and the purity be considered, but the operating costs as well. The use of internal spreadsheet will enhance the level of possible flowsheet and economical calculations. Case Studies for Sensitivity Analysis.	2 hours	
9	DISTILLATION COLUMN ADDITIONAL ASSIGNMENT Without a guided exercise, build elements of a petrochemical plant using the unit operations and tools described in the previous exercise.	4 hours	